

0020242707, 0020242708

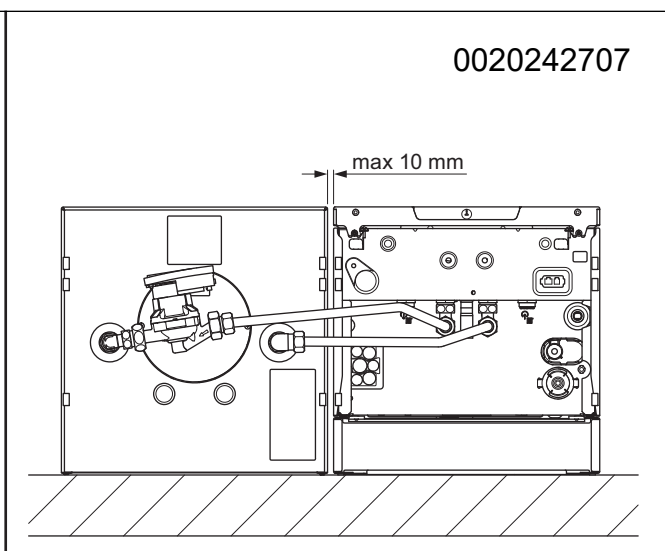

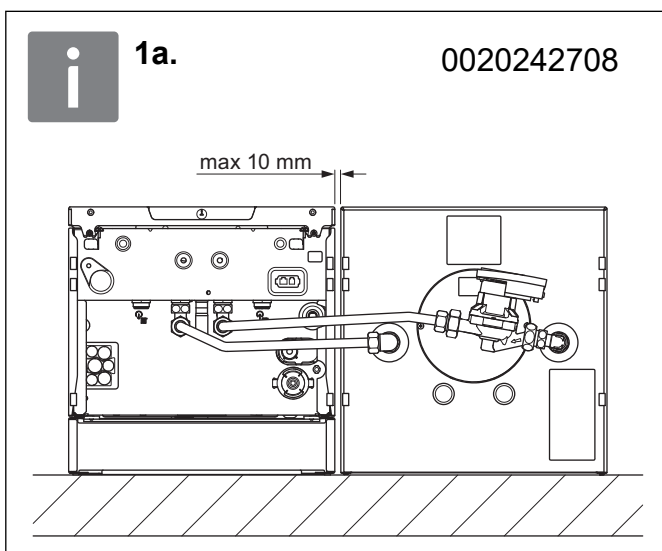

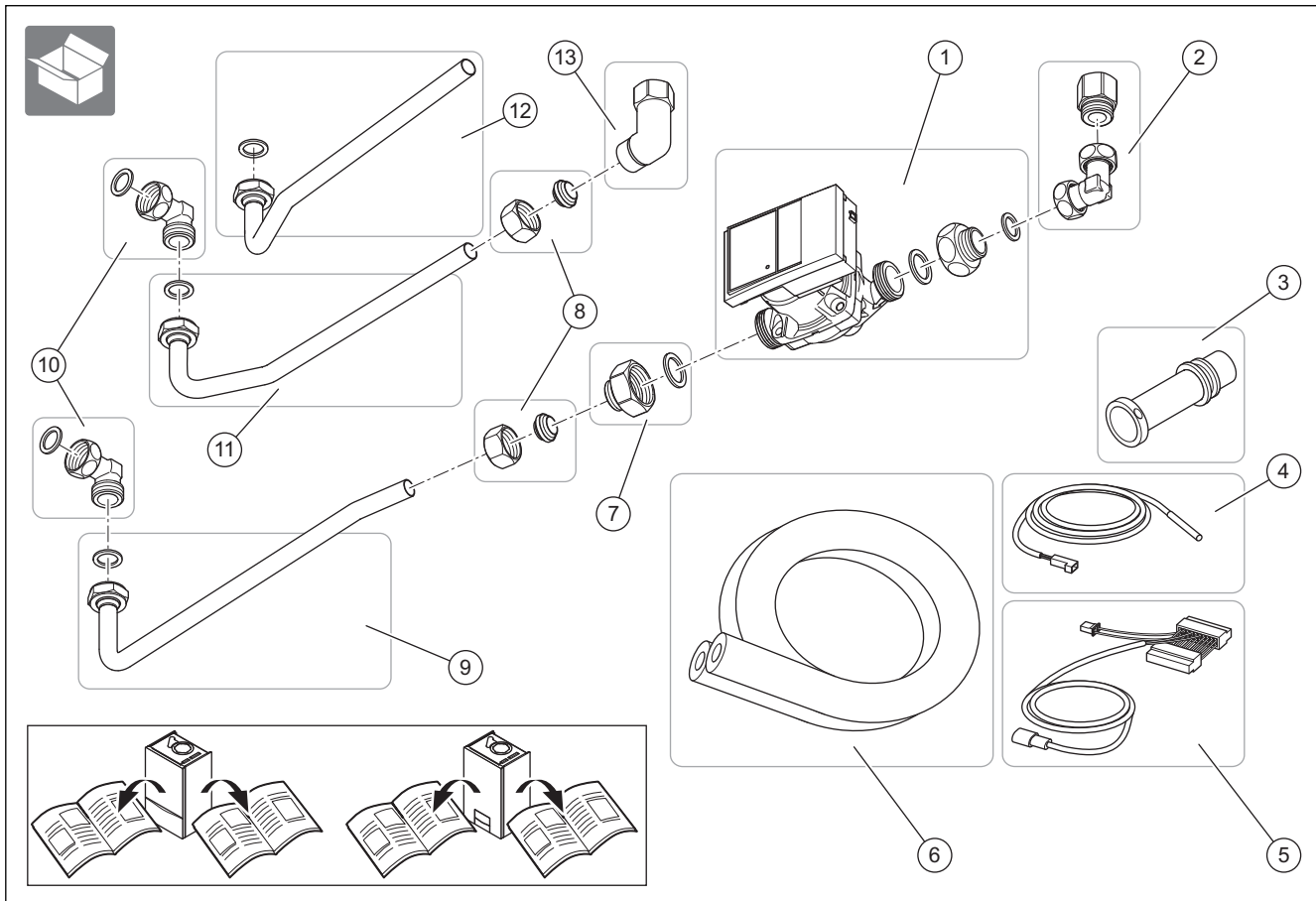

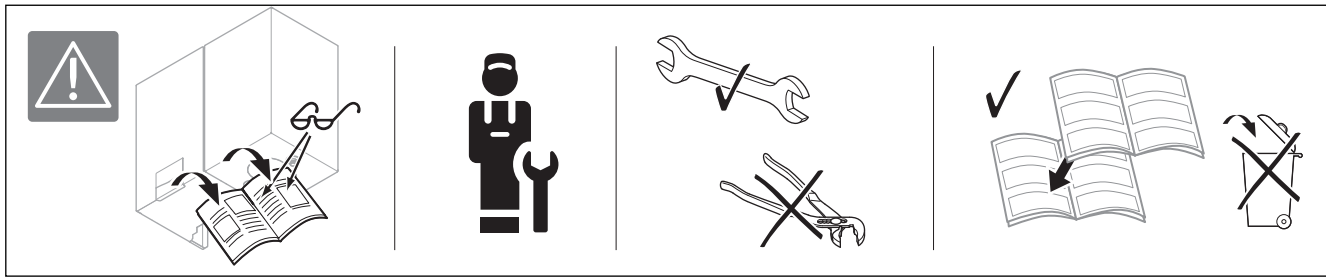
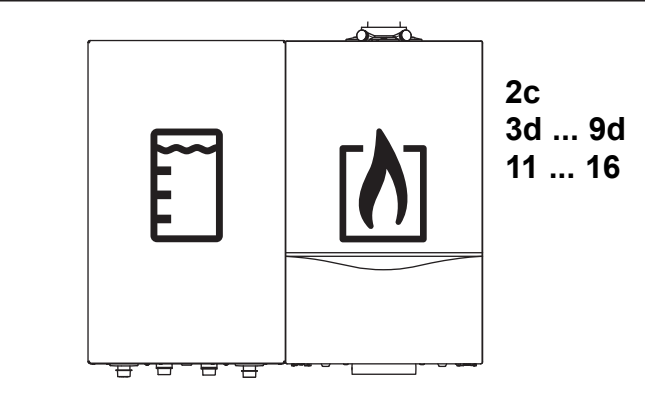
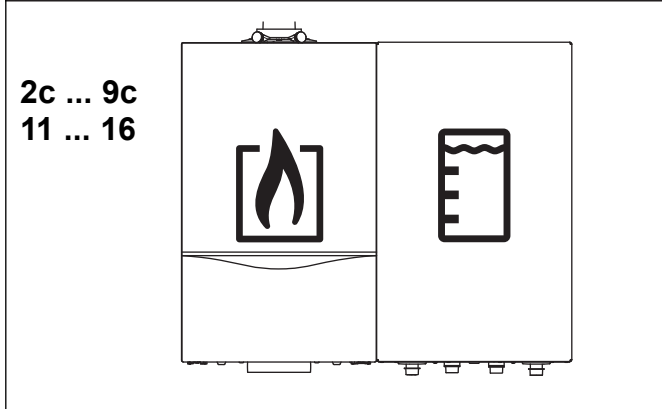
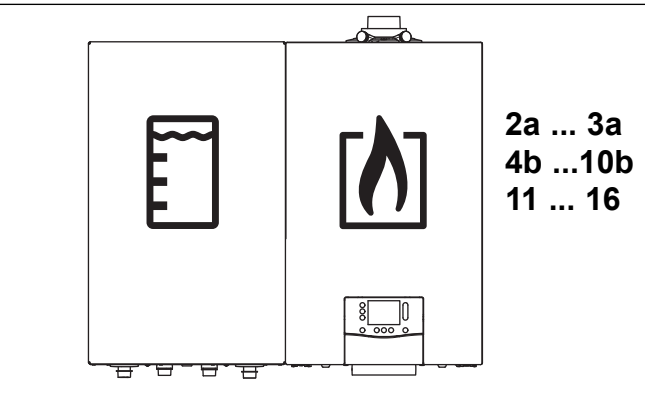
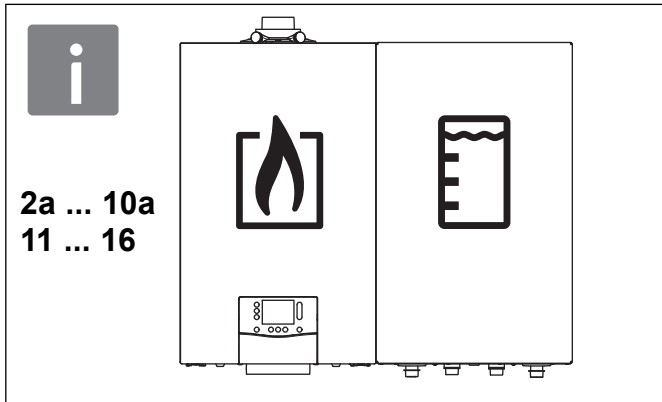
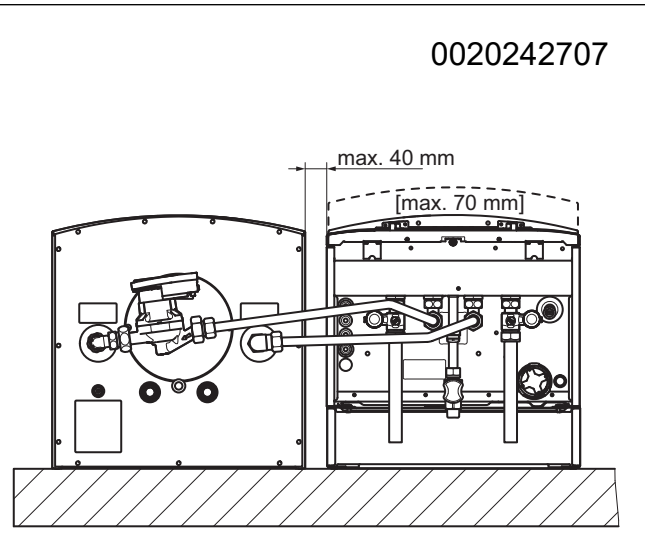
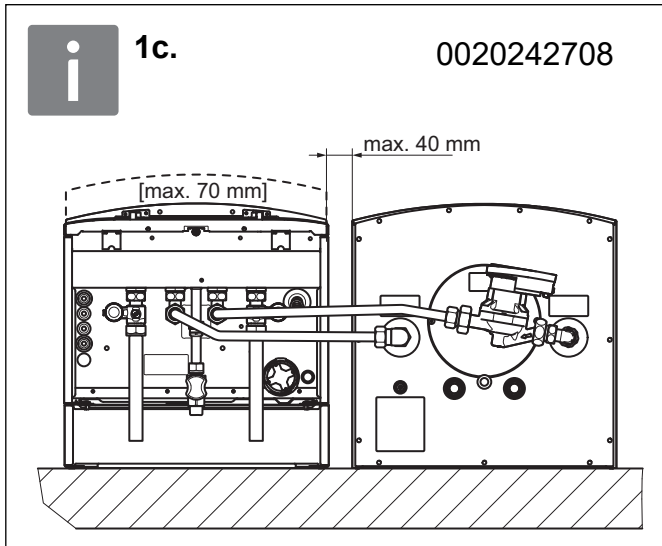
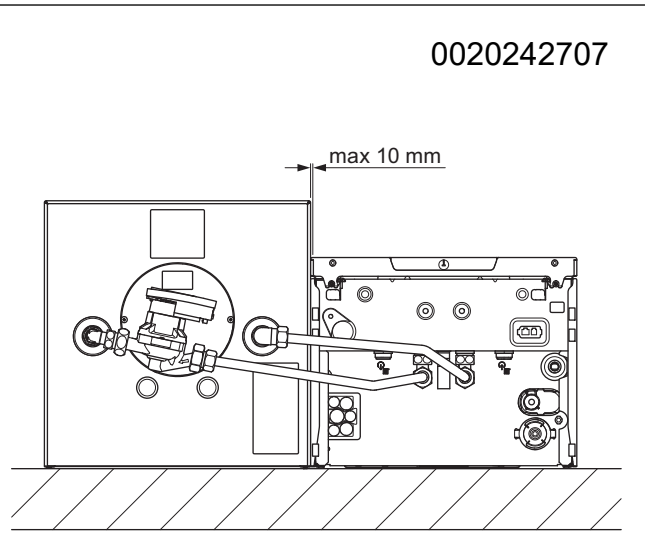
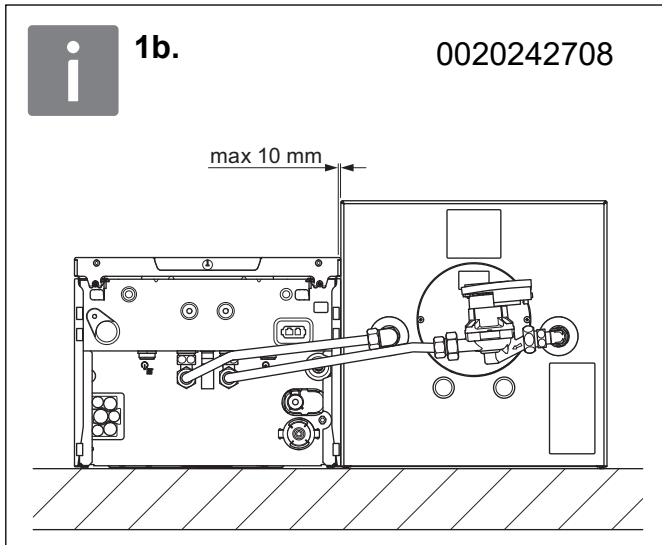
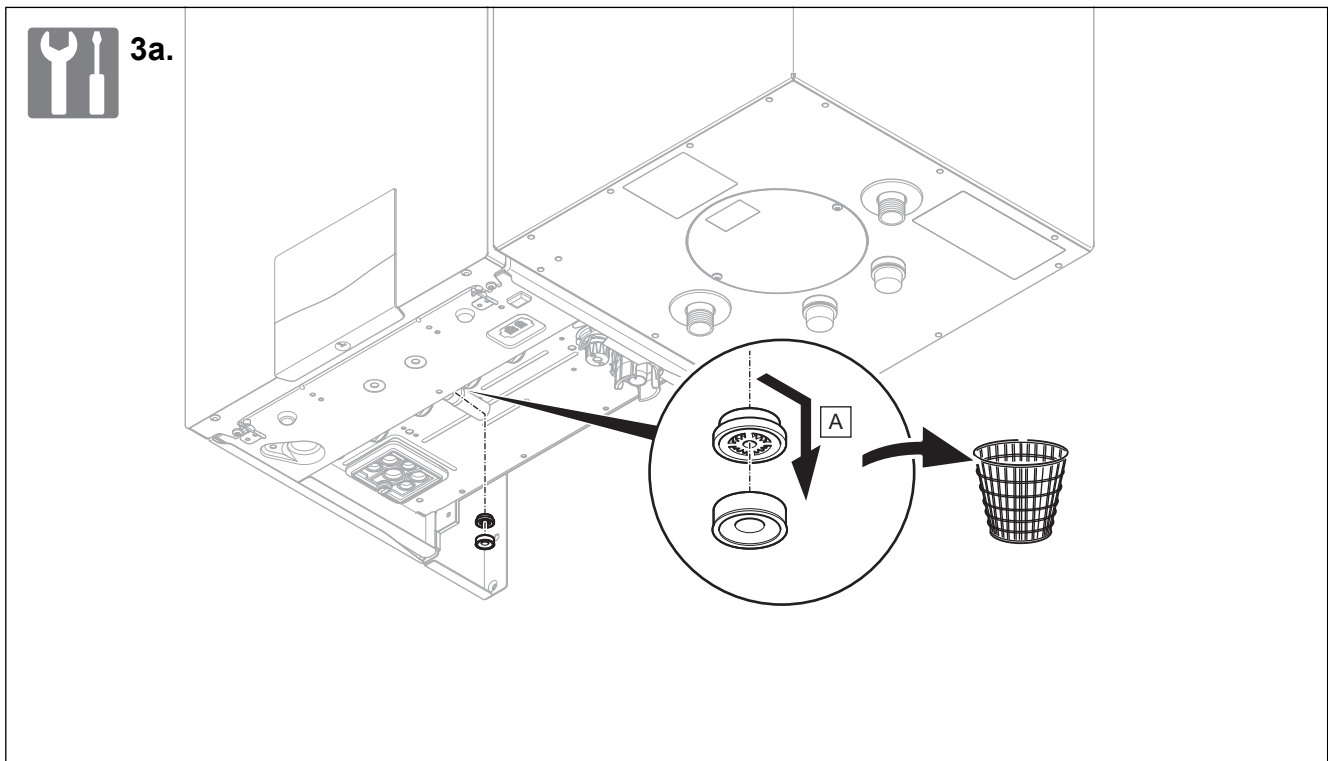
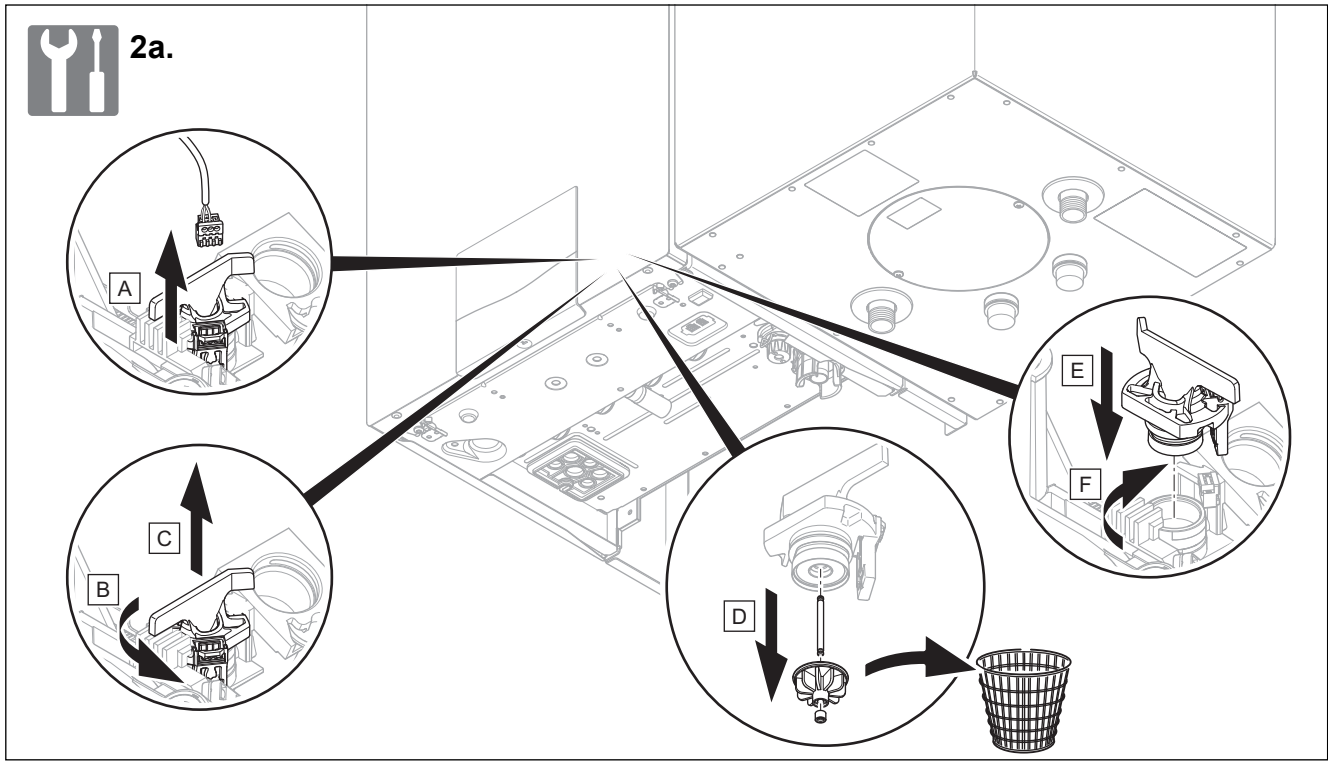
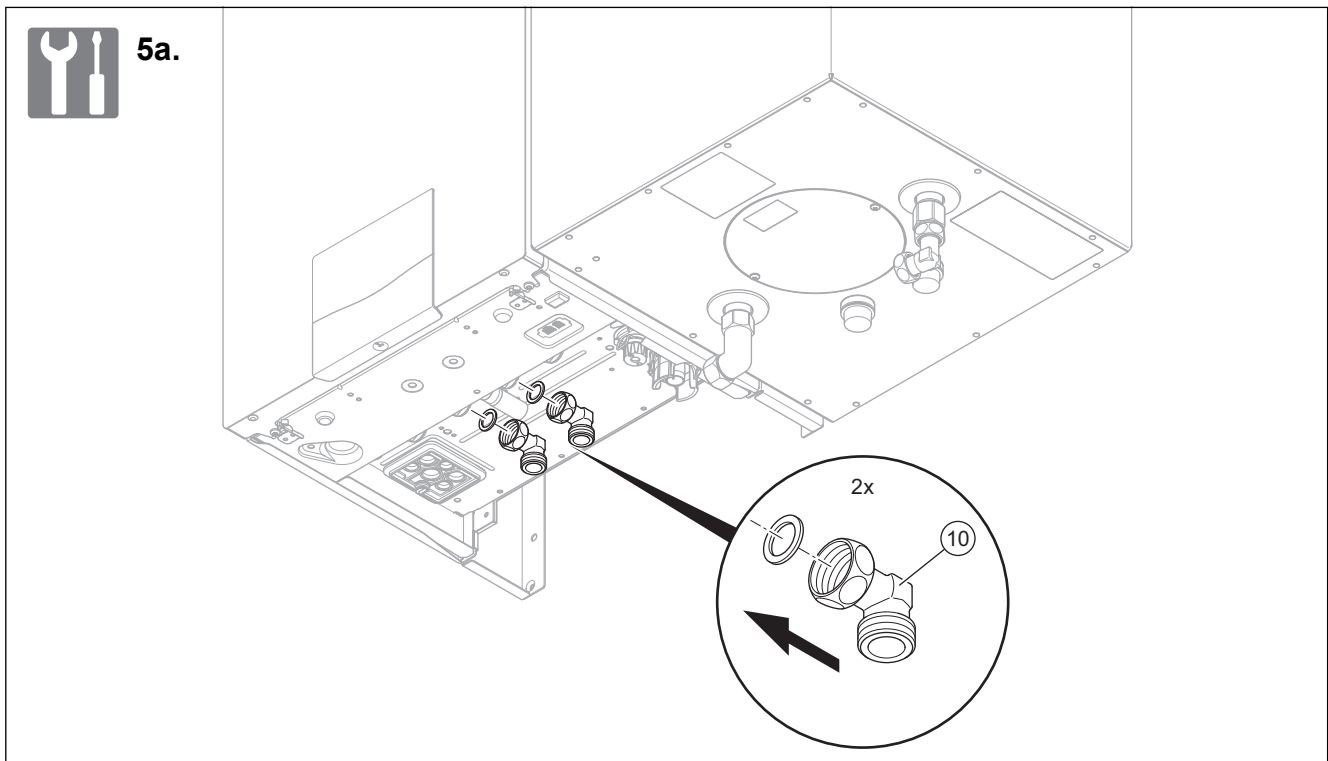
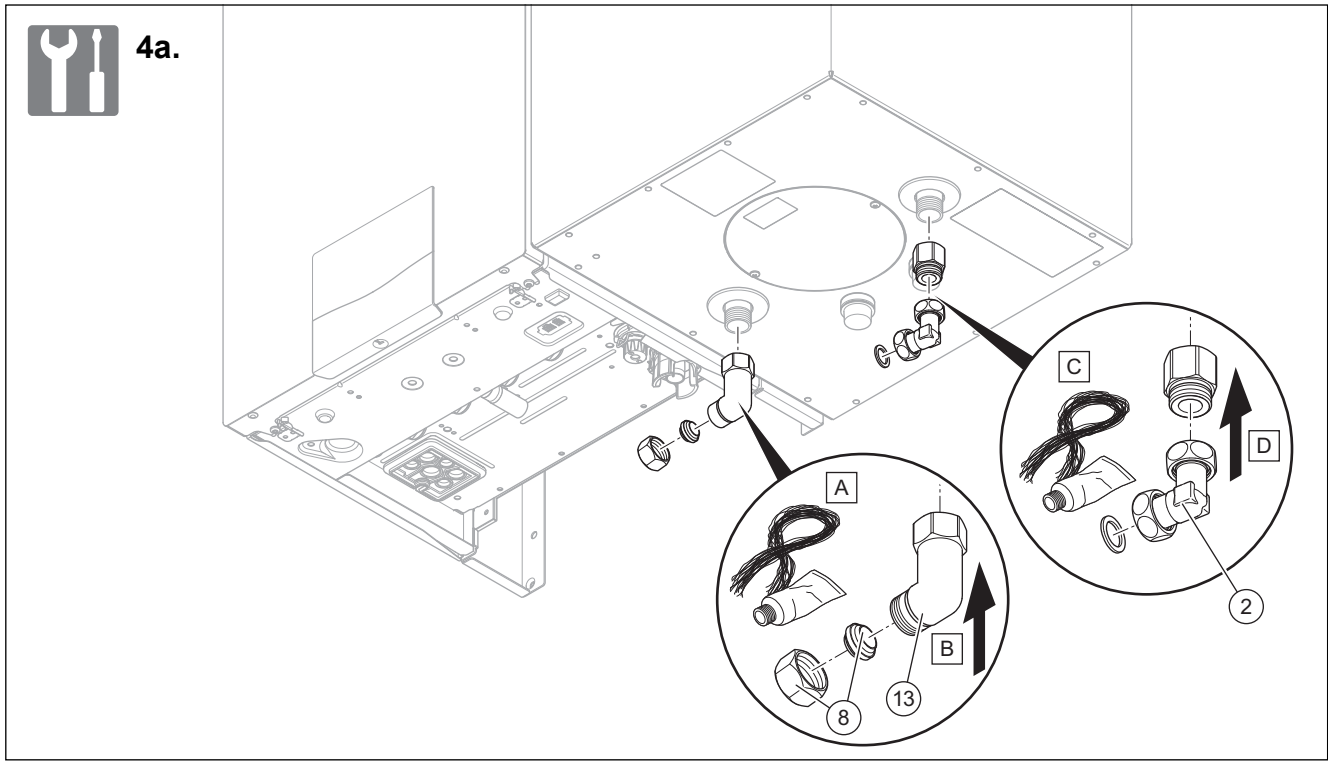



6a.

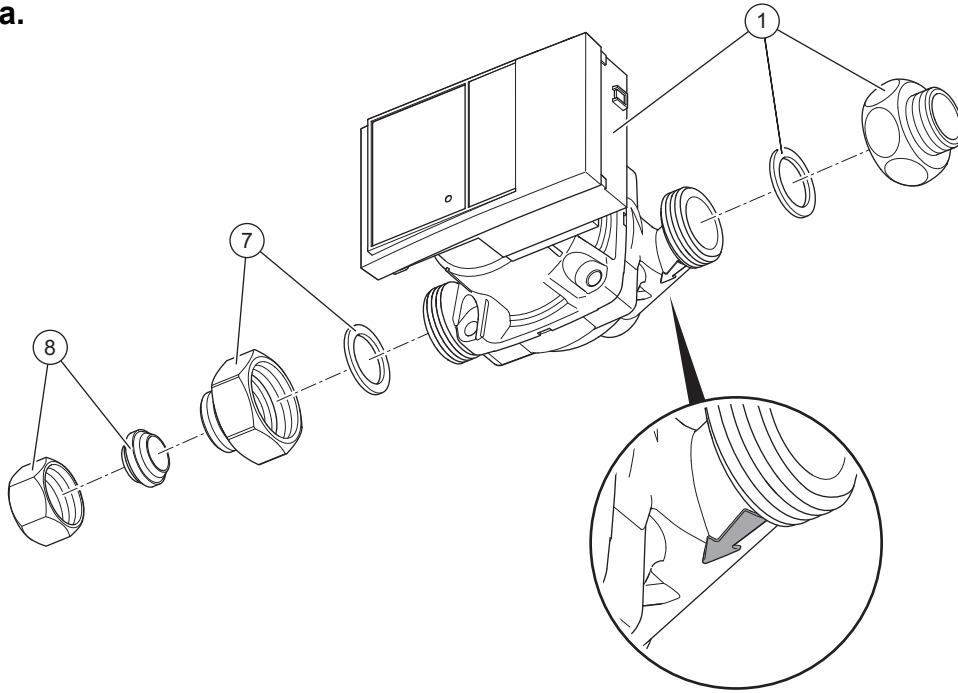

7a.

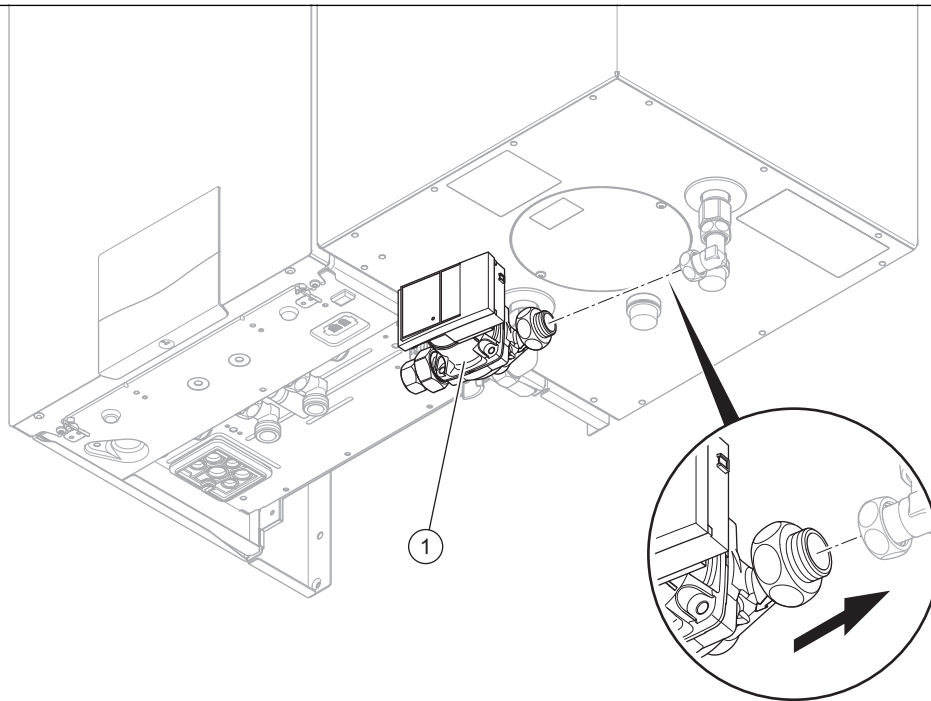

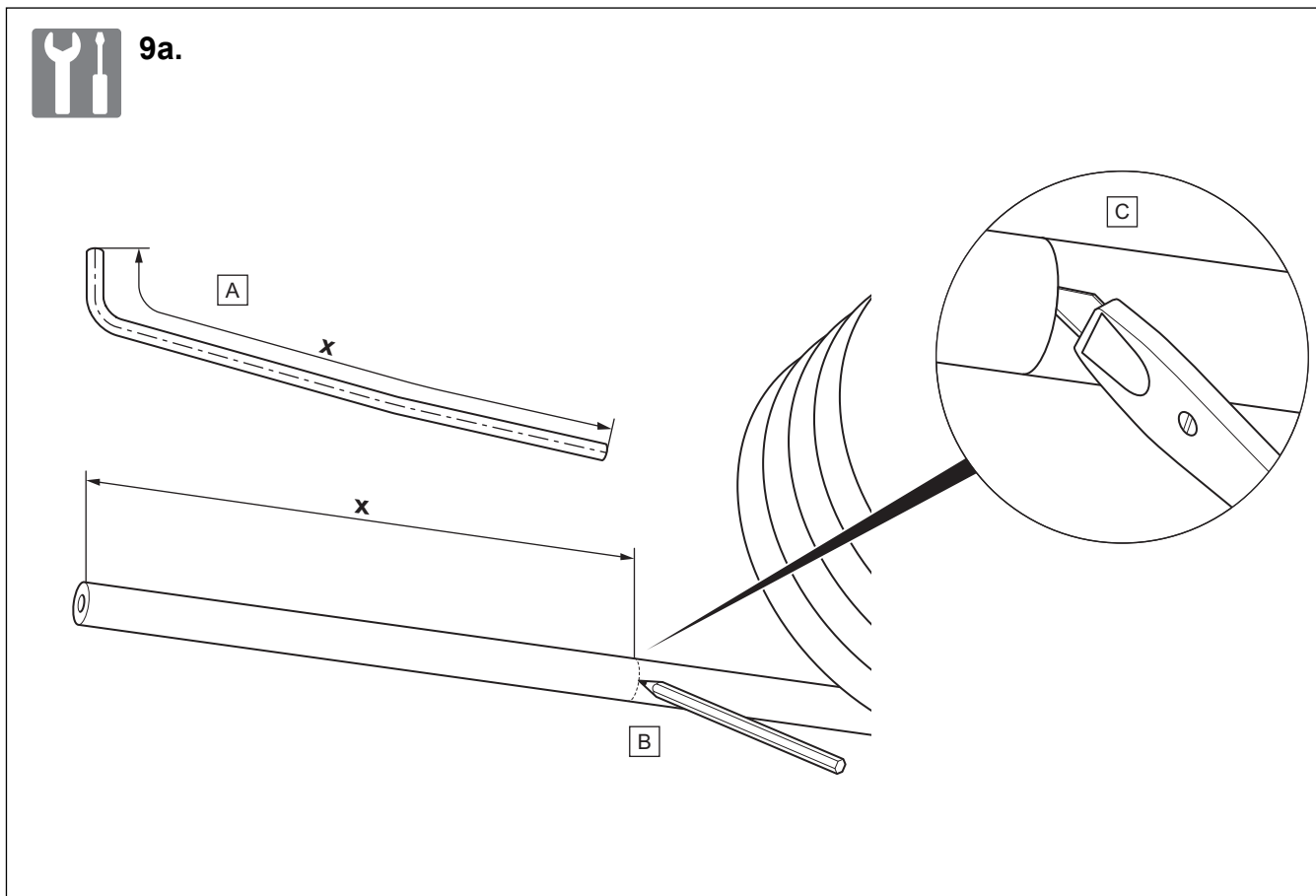
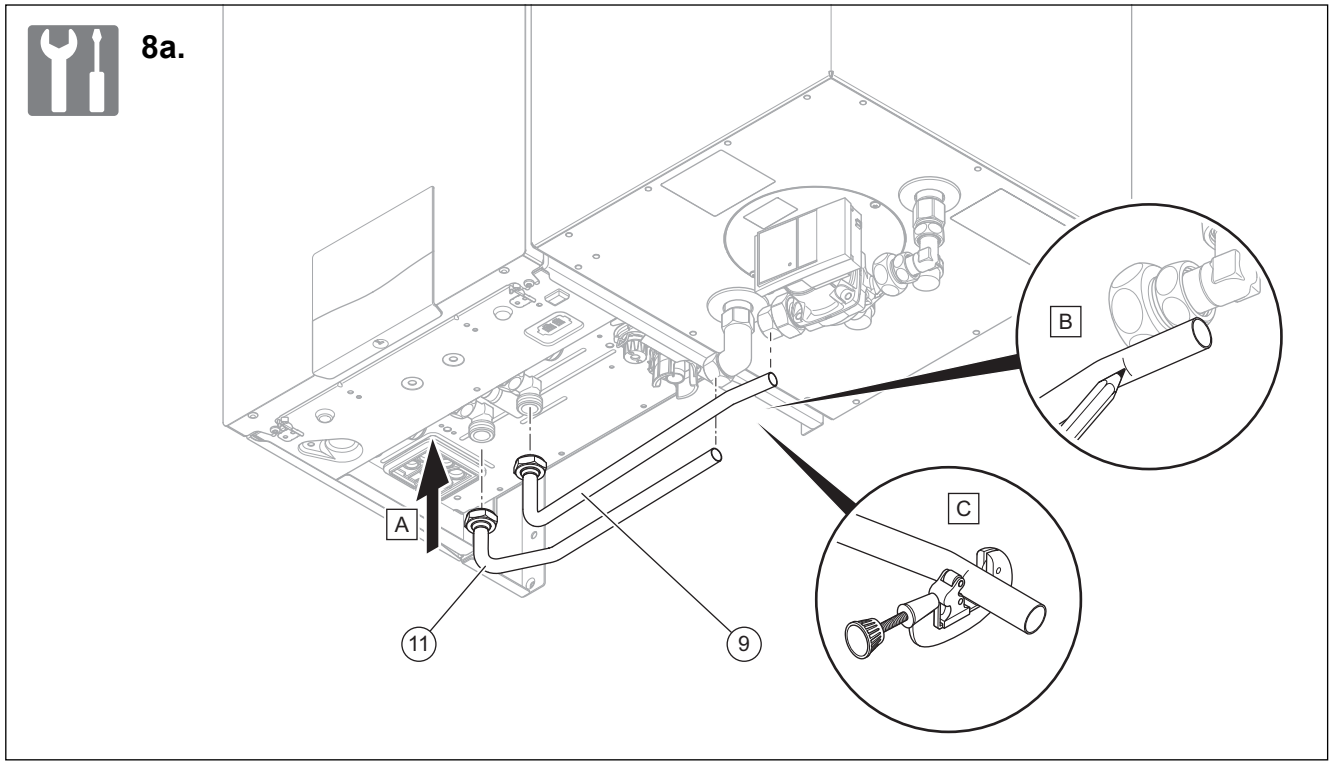

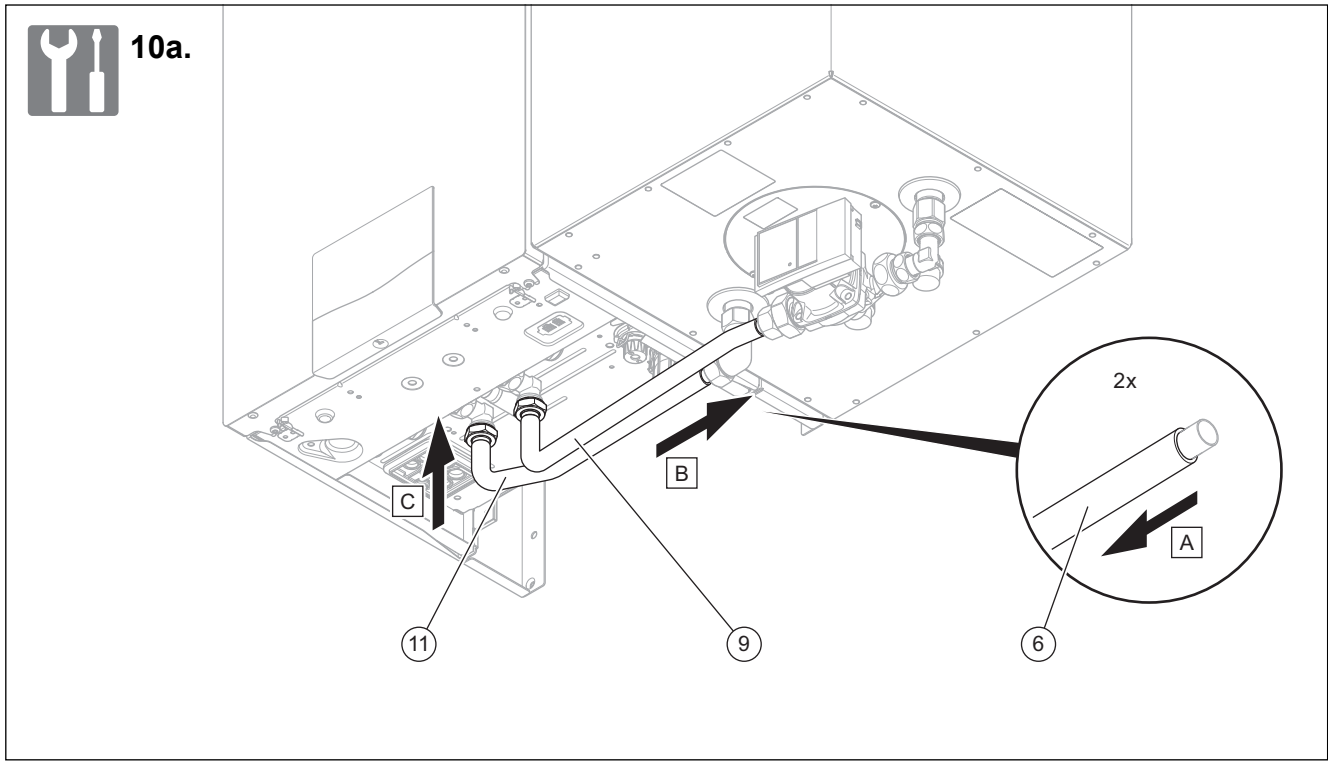

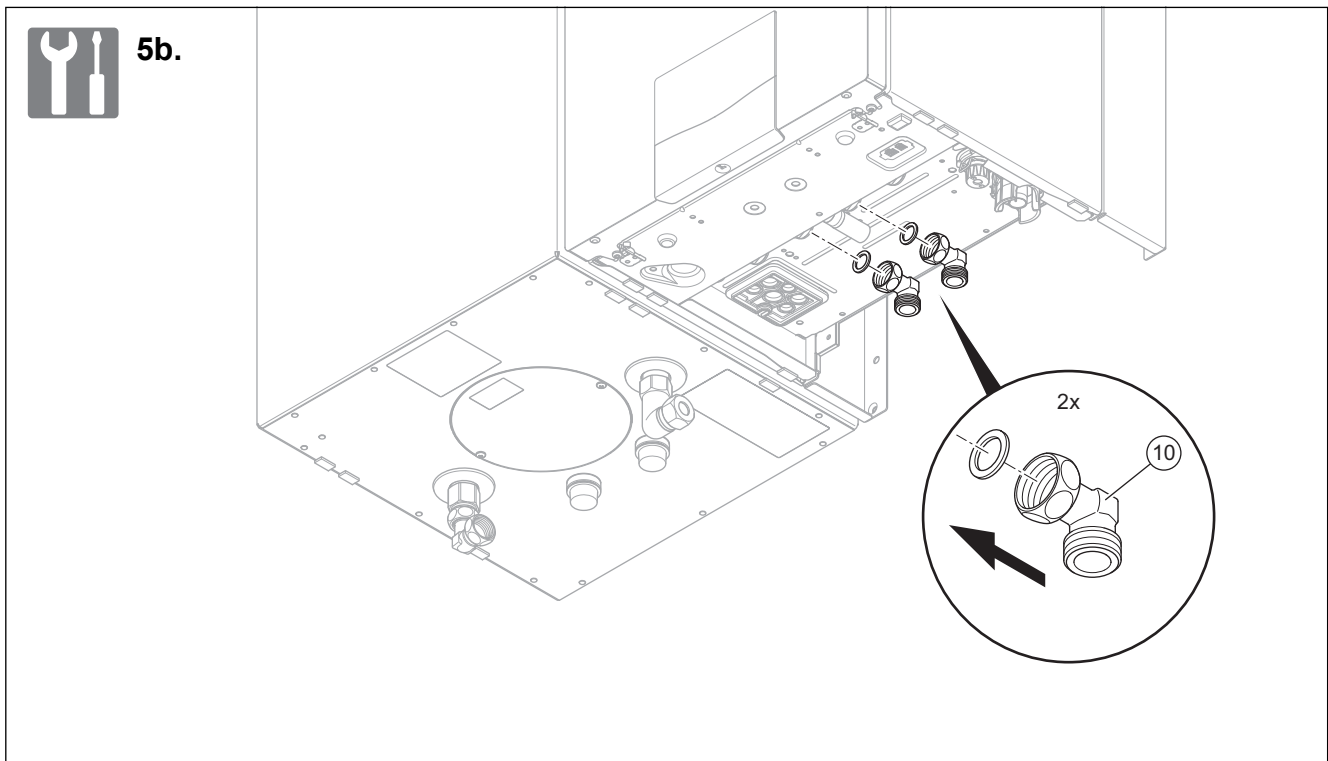
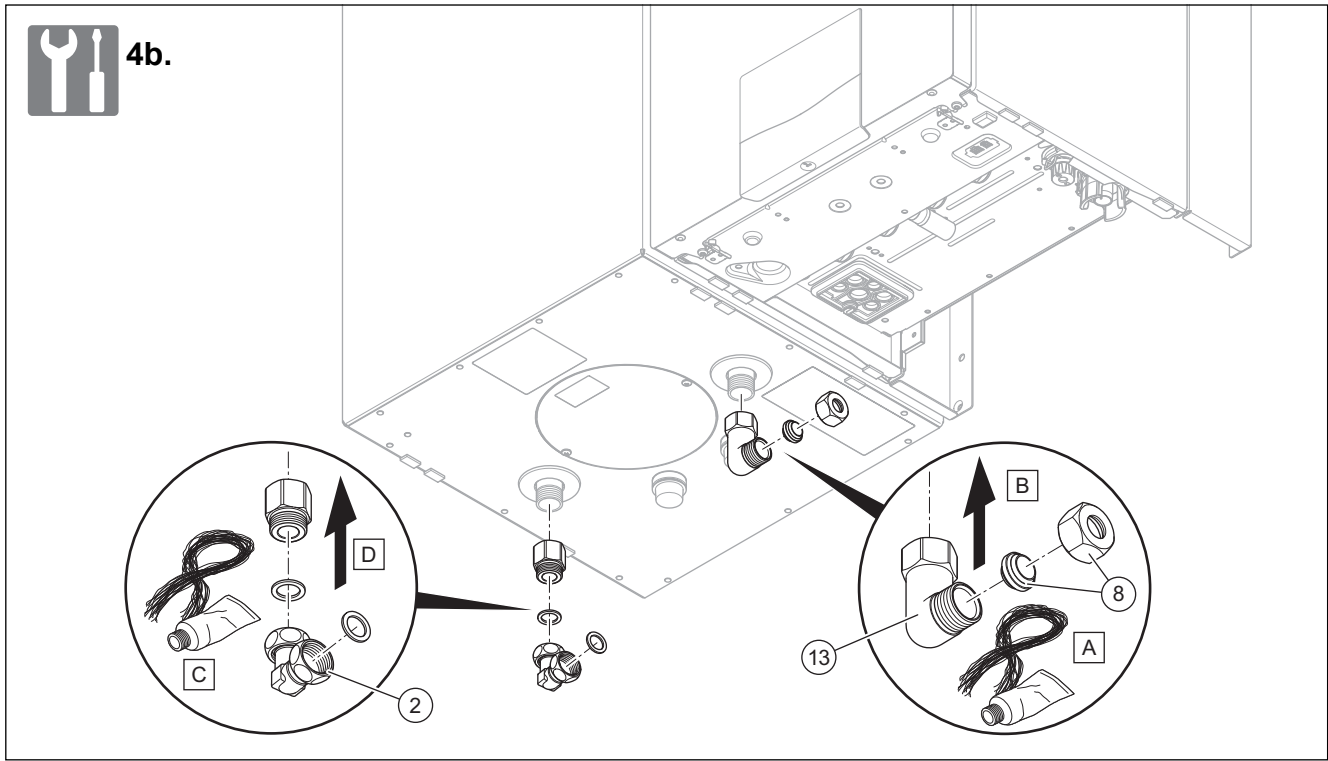

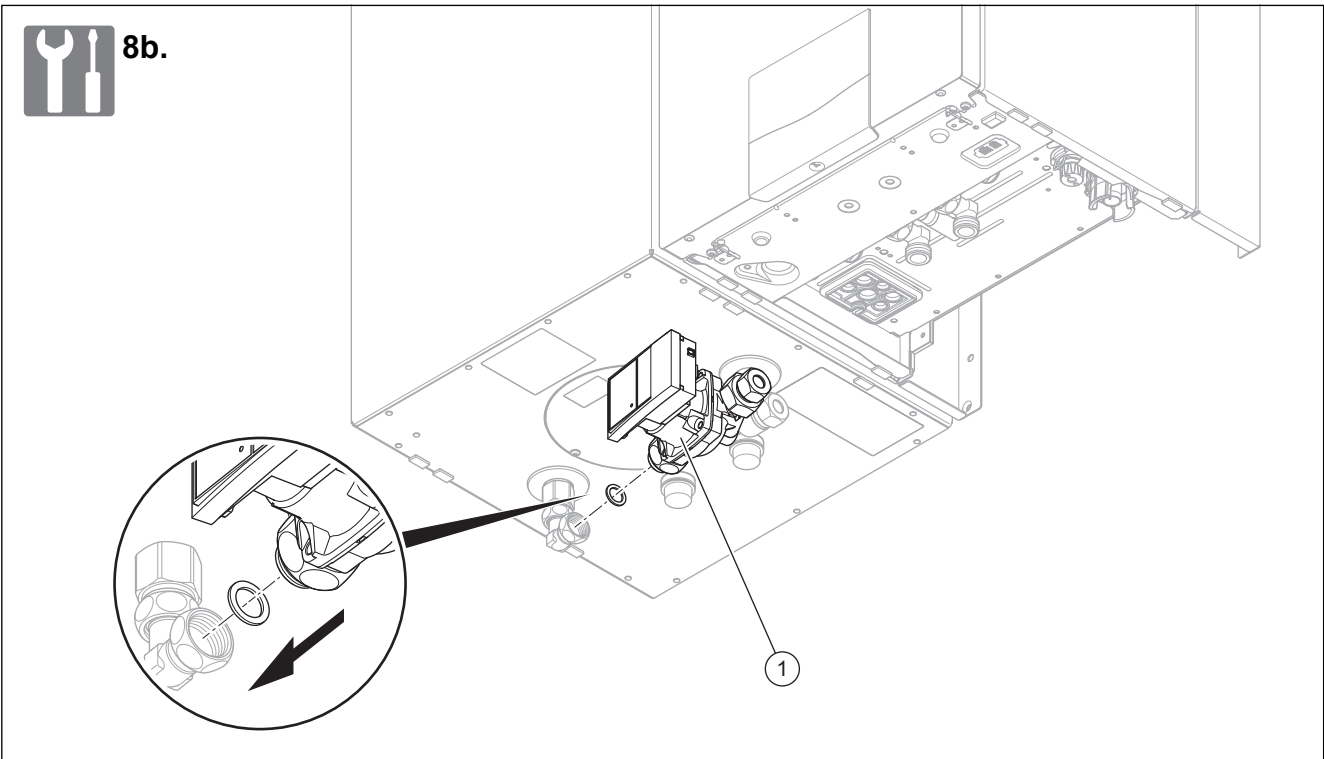
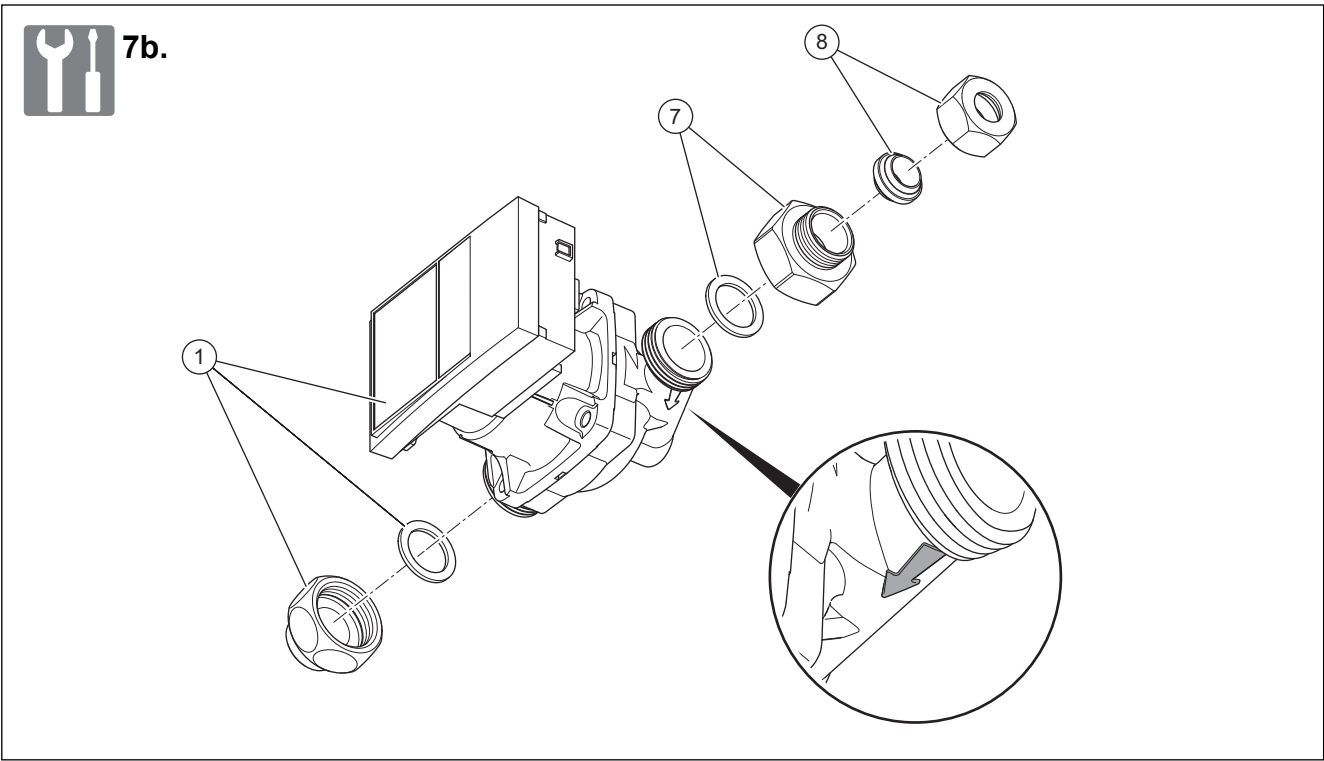



9b.

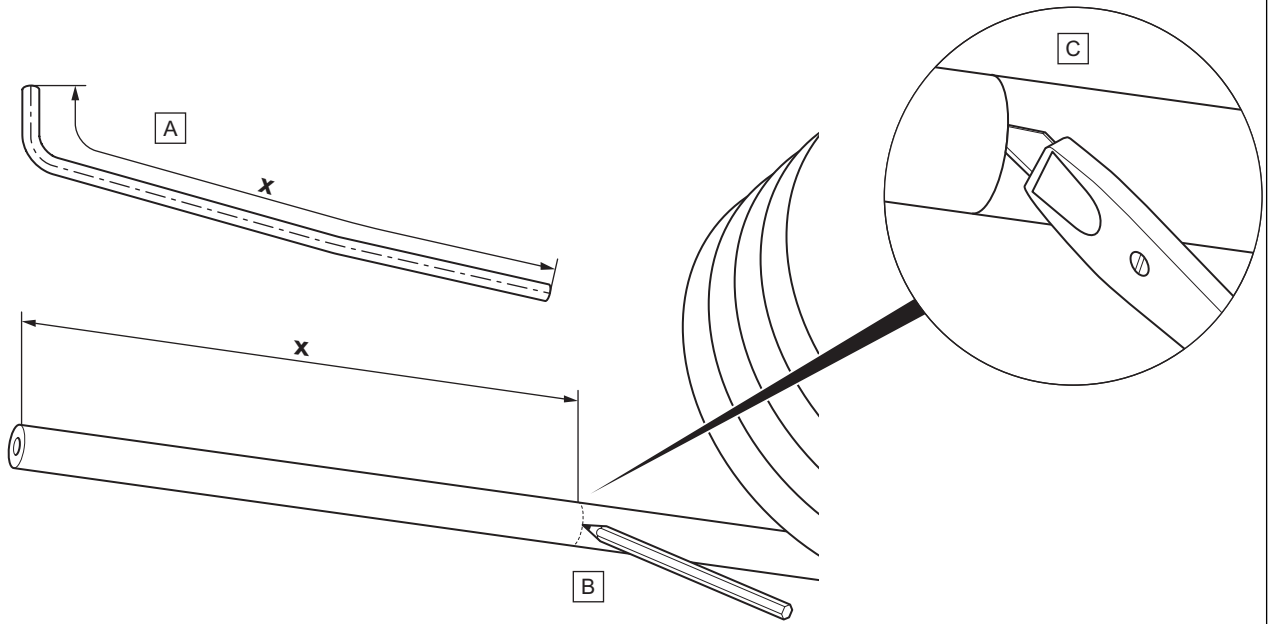

10b.

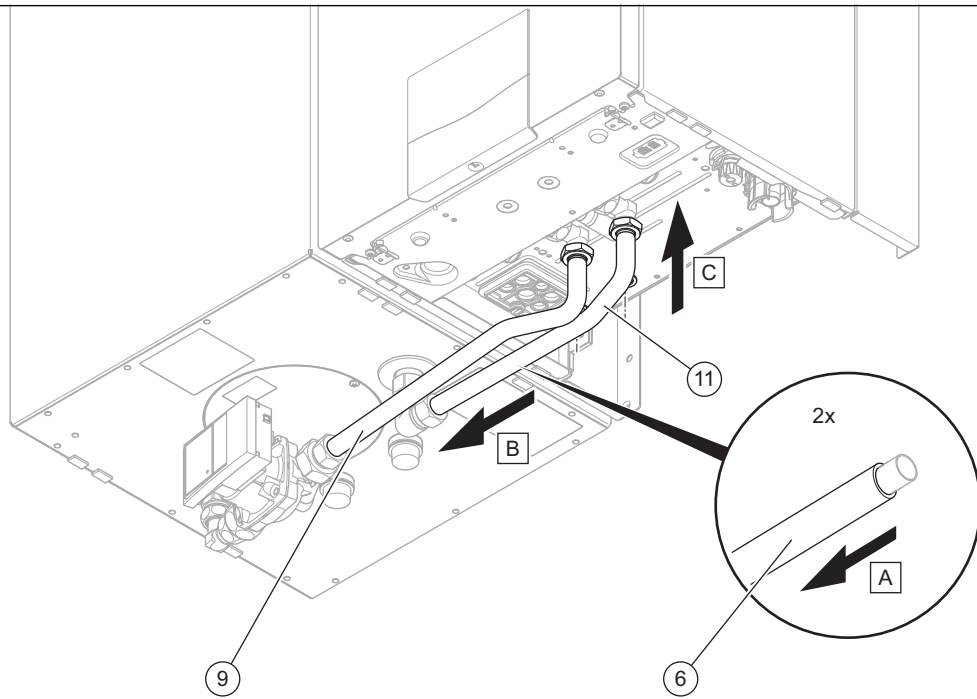

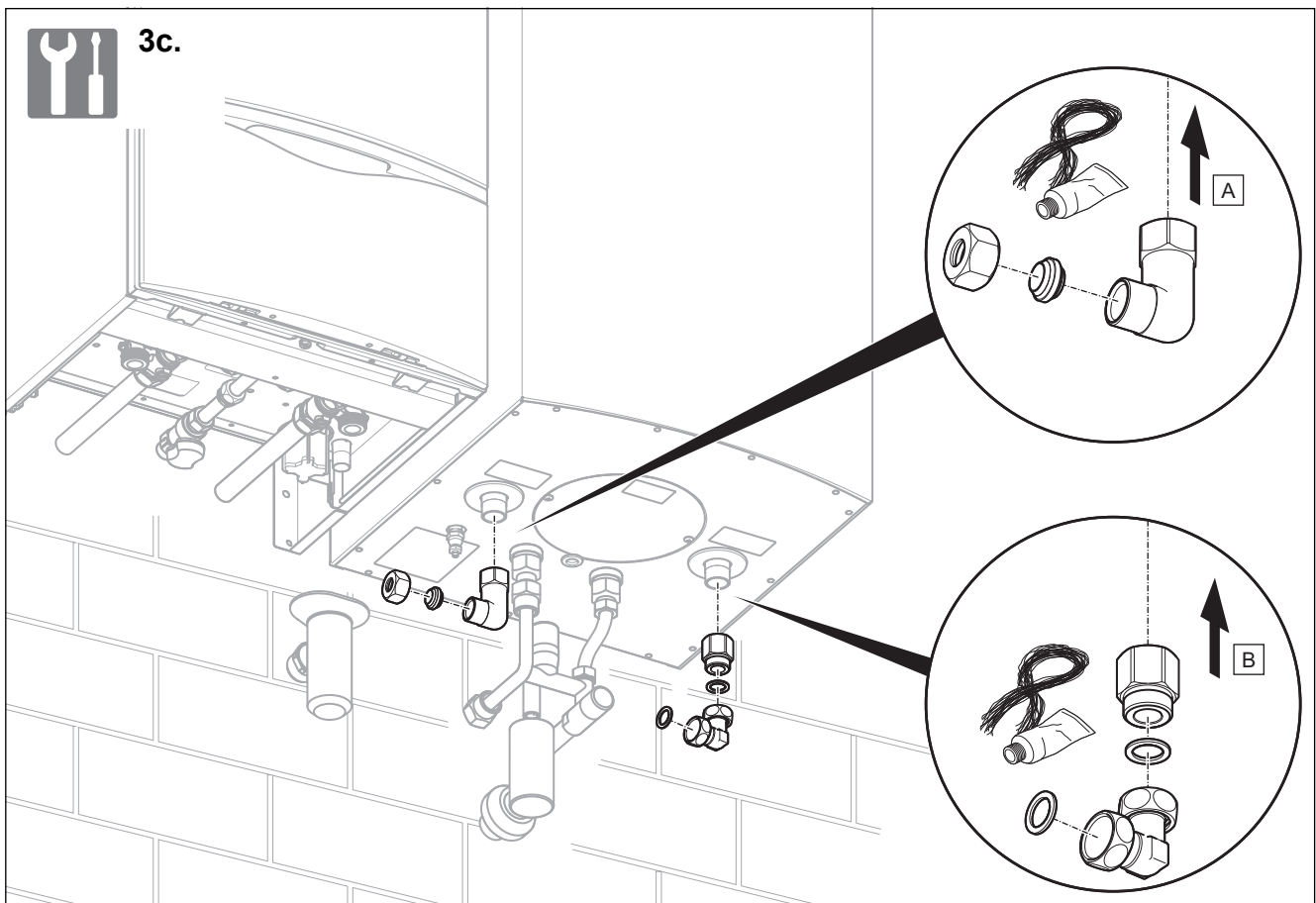
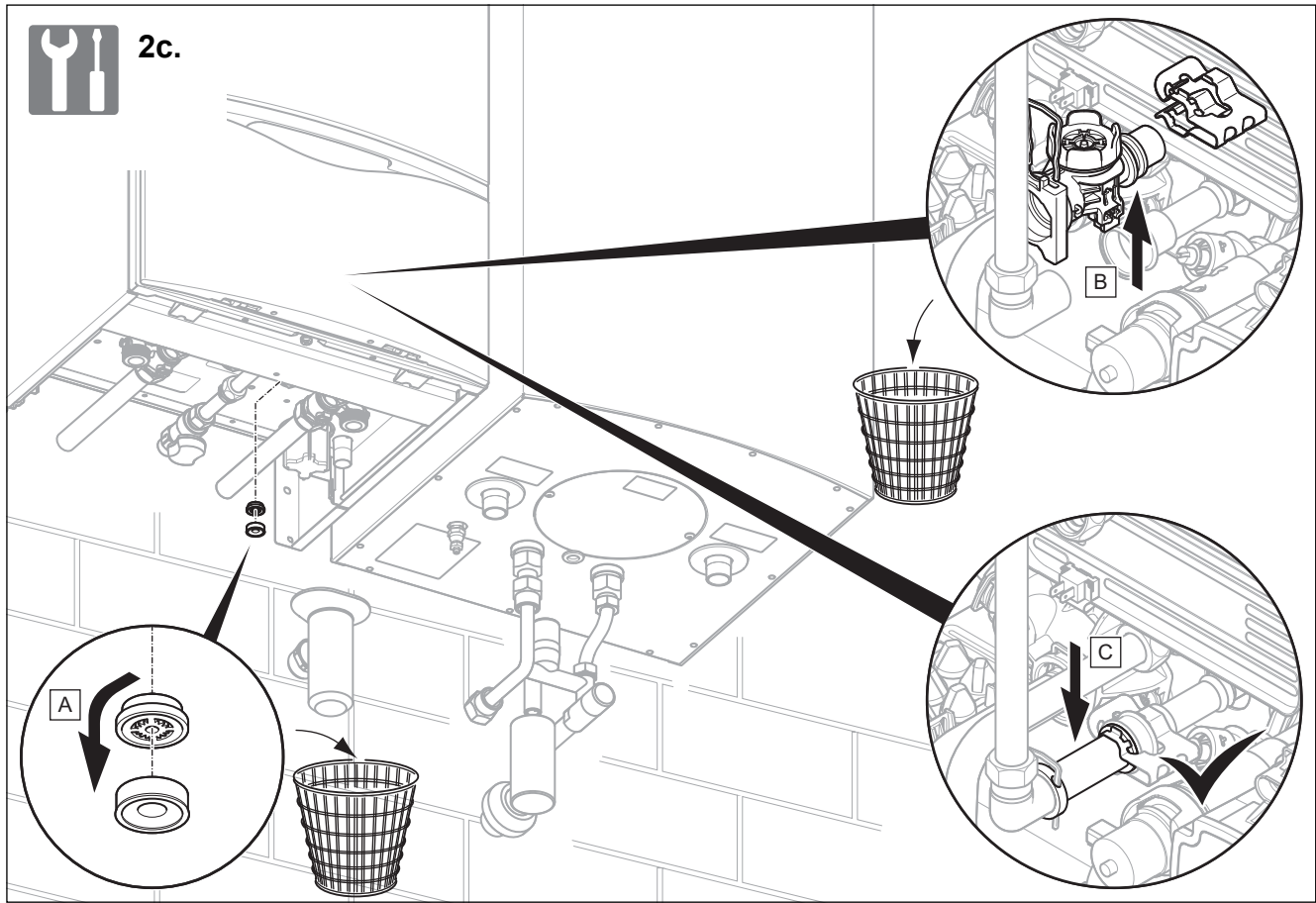

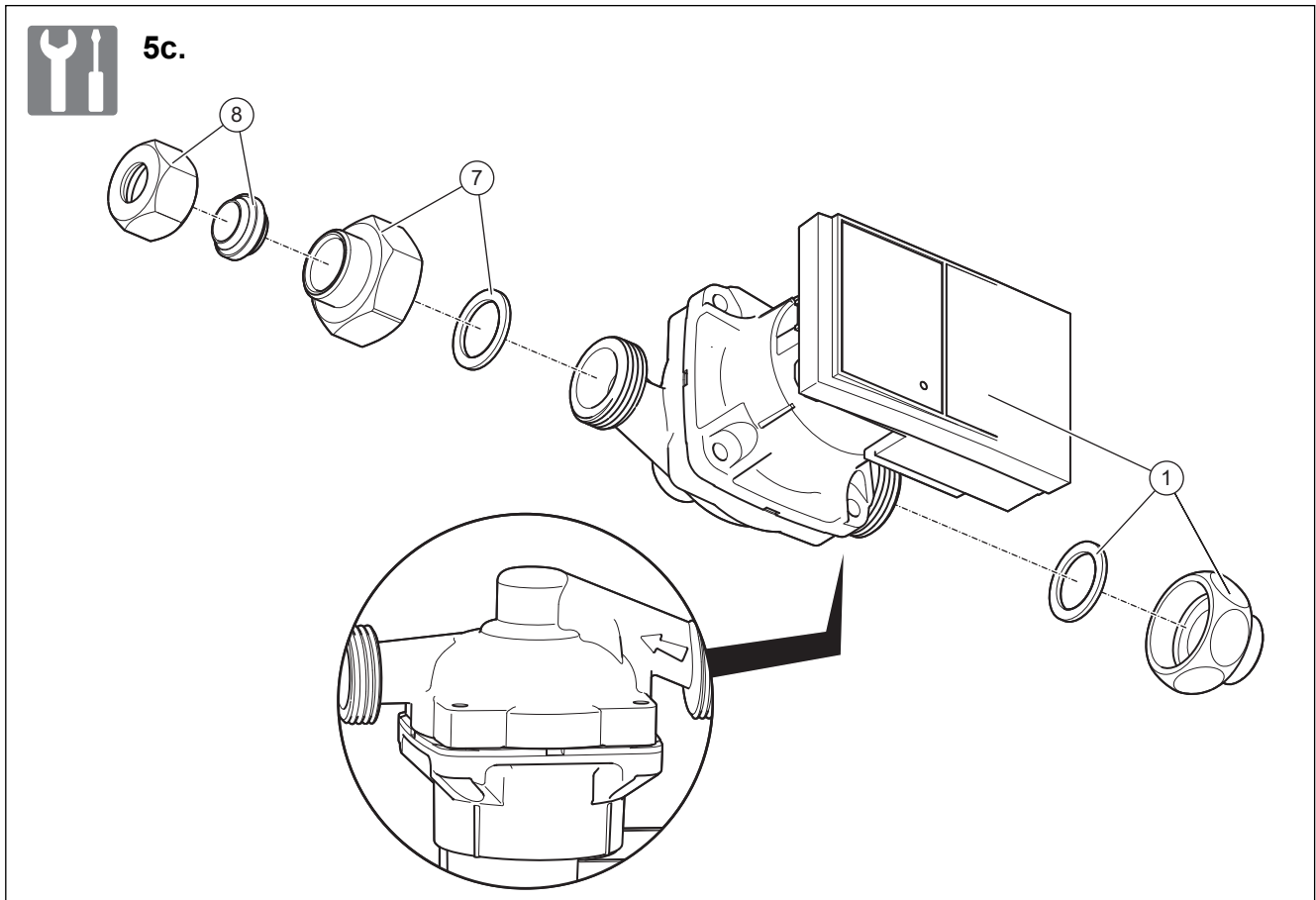
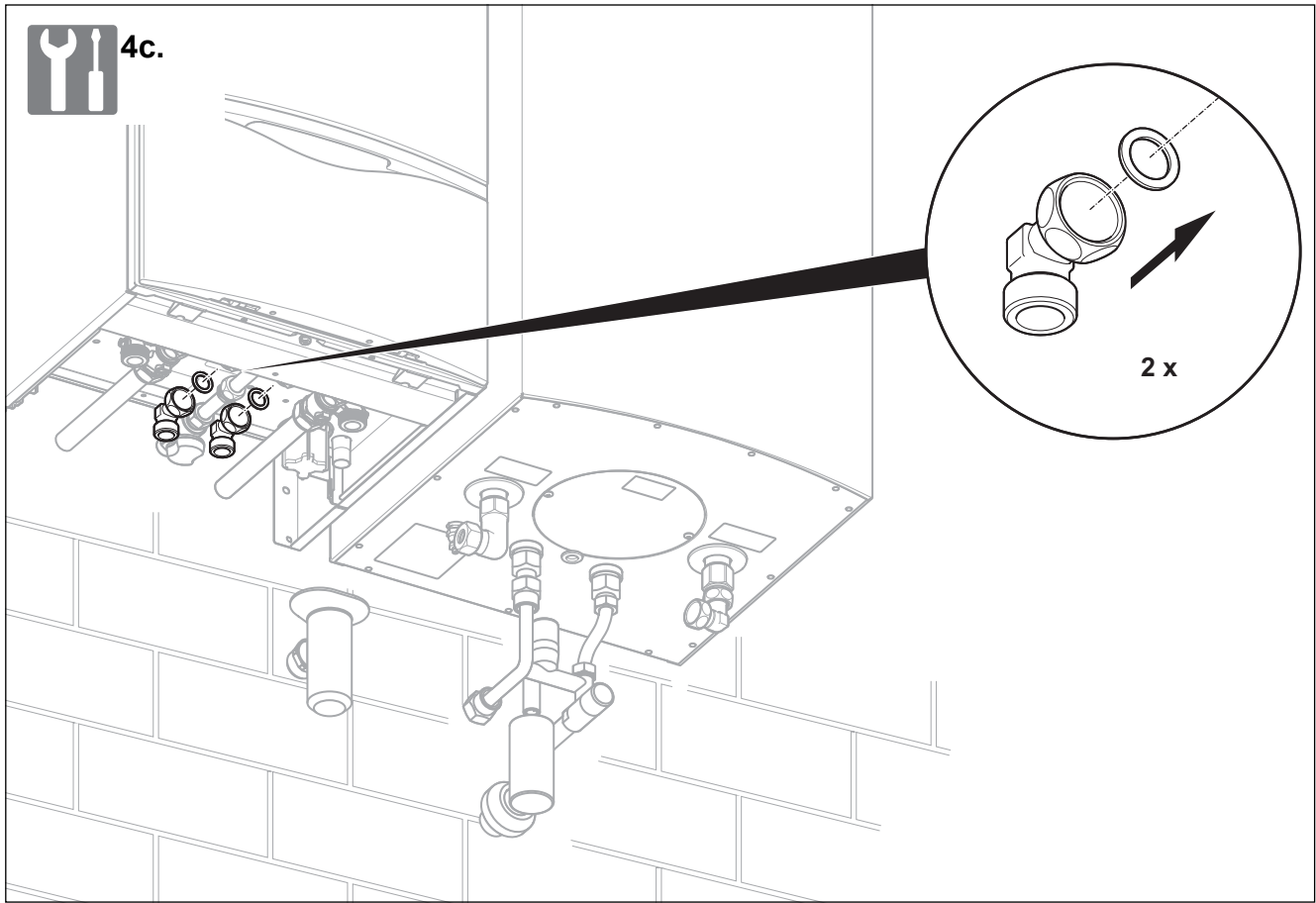

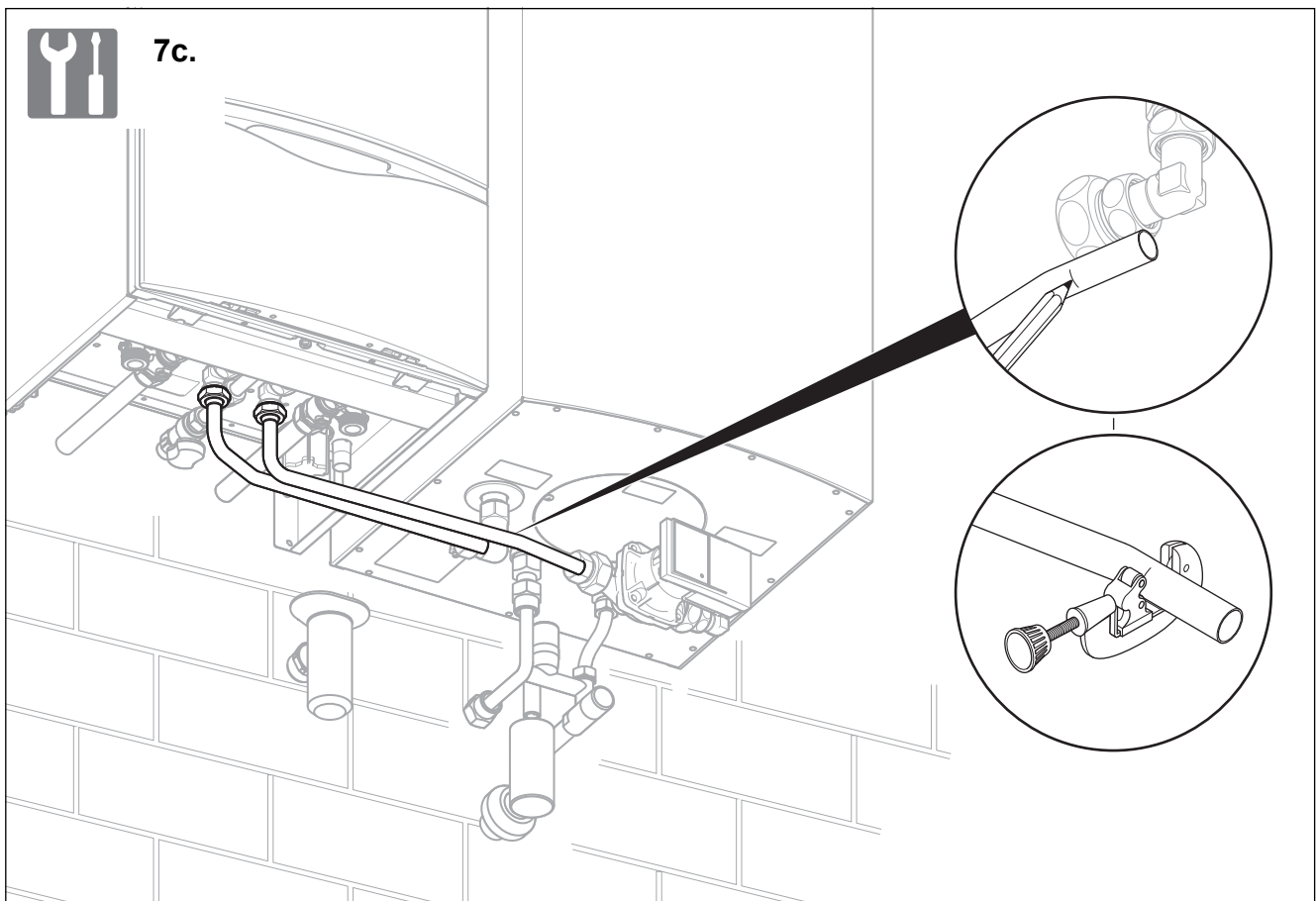
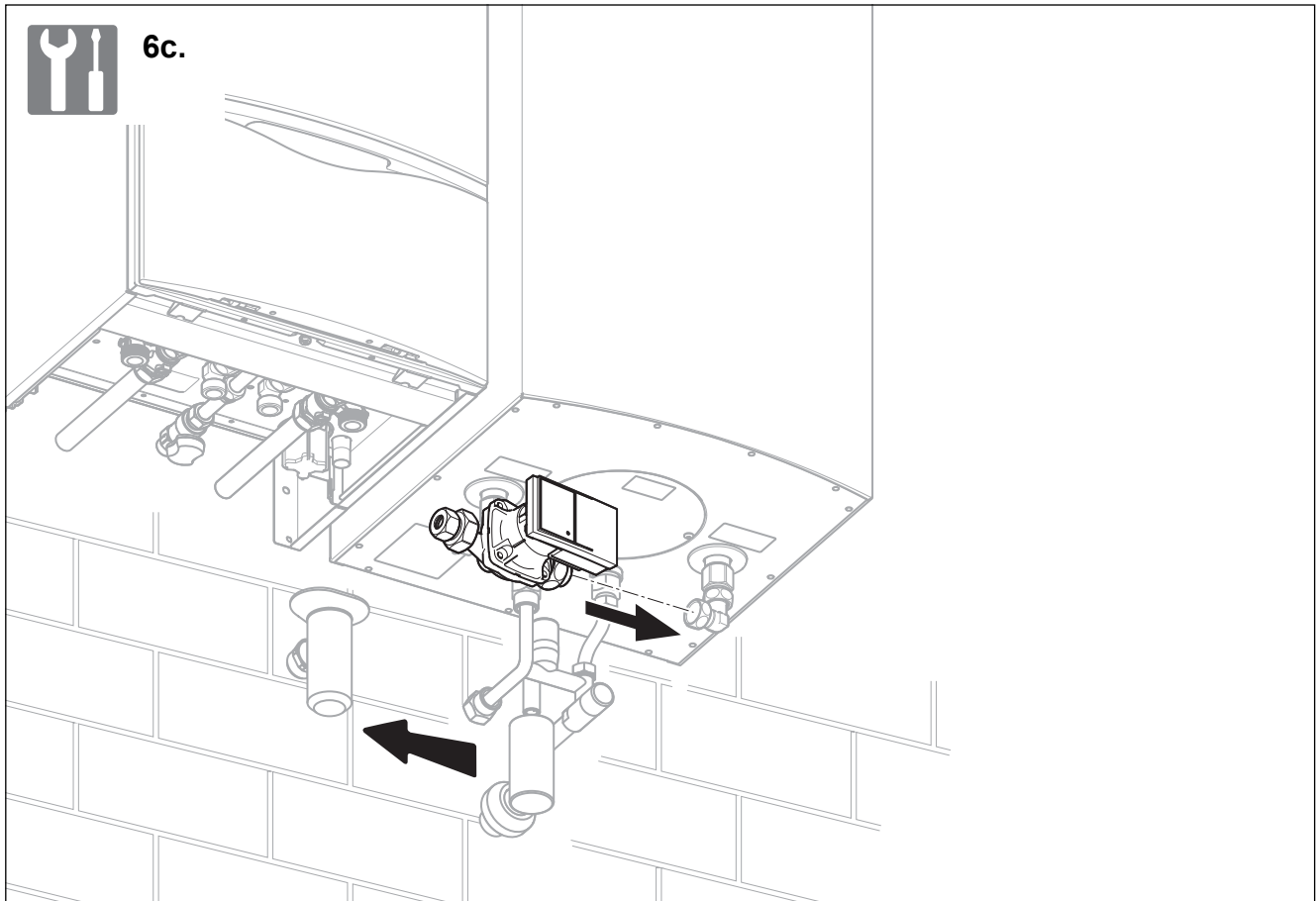

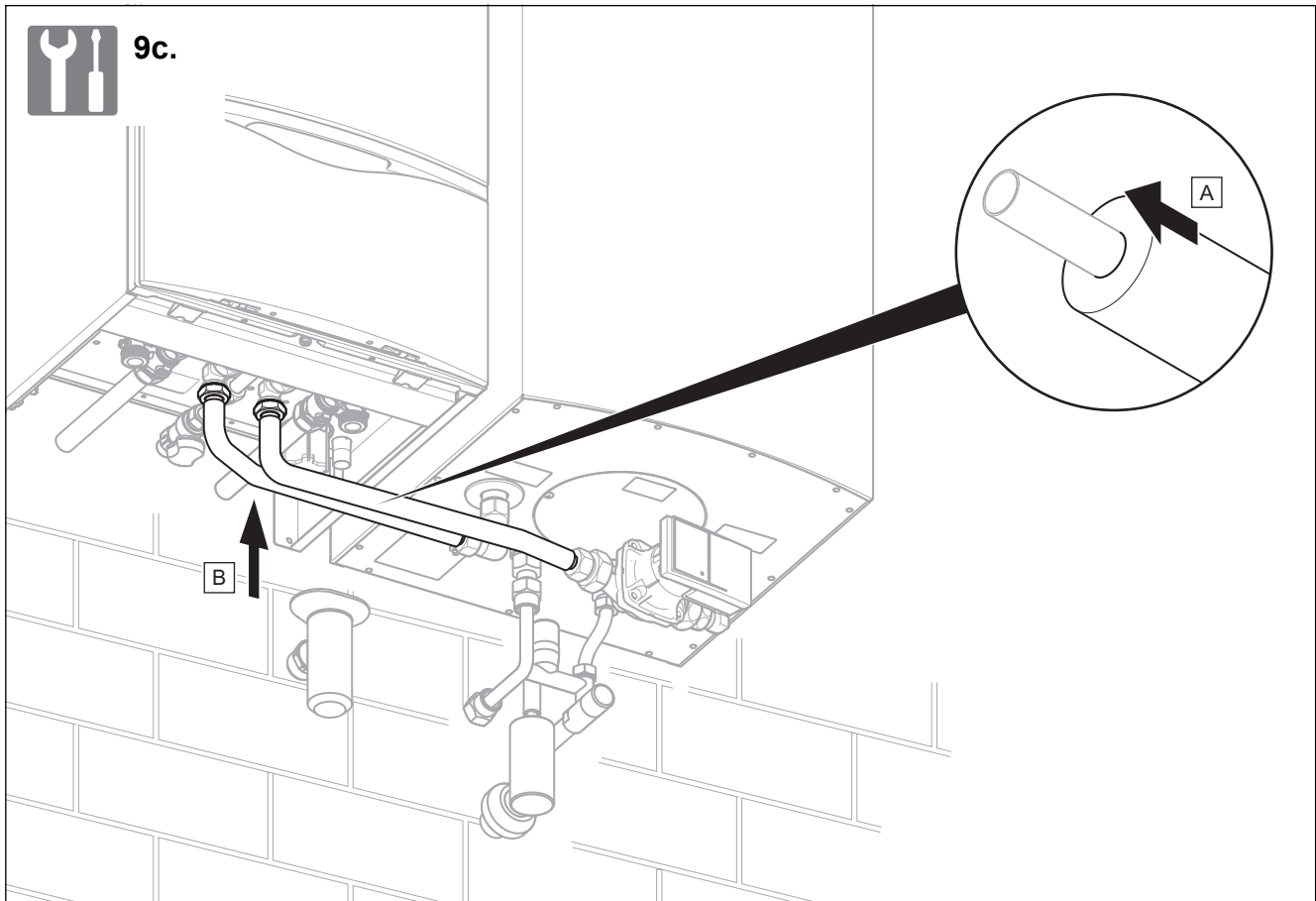
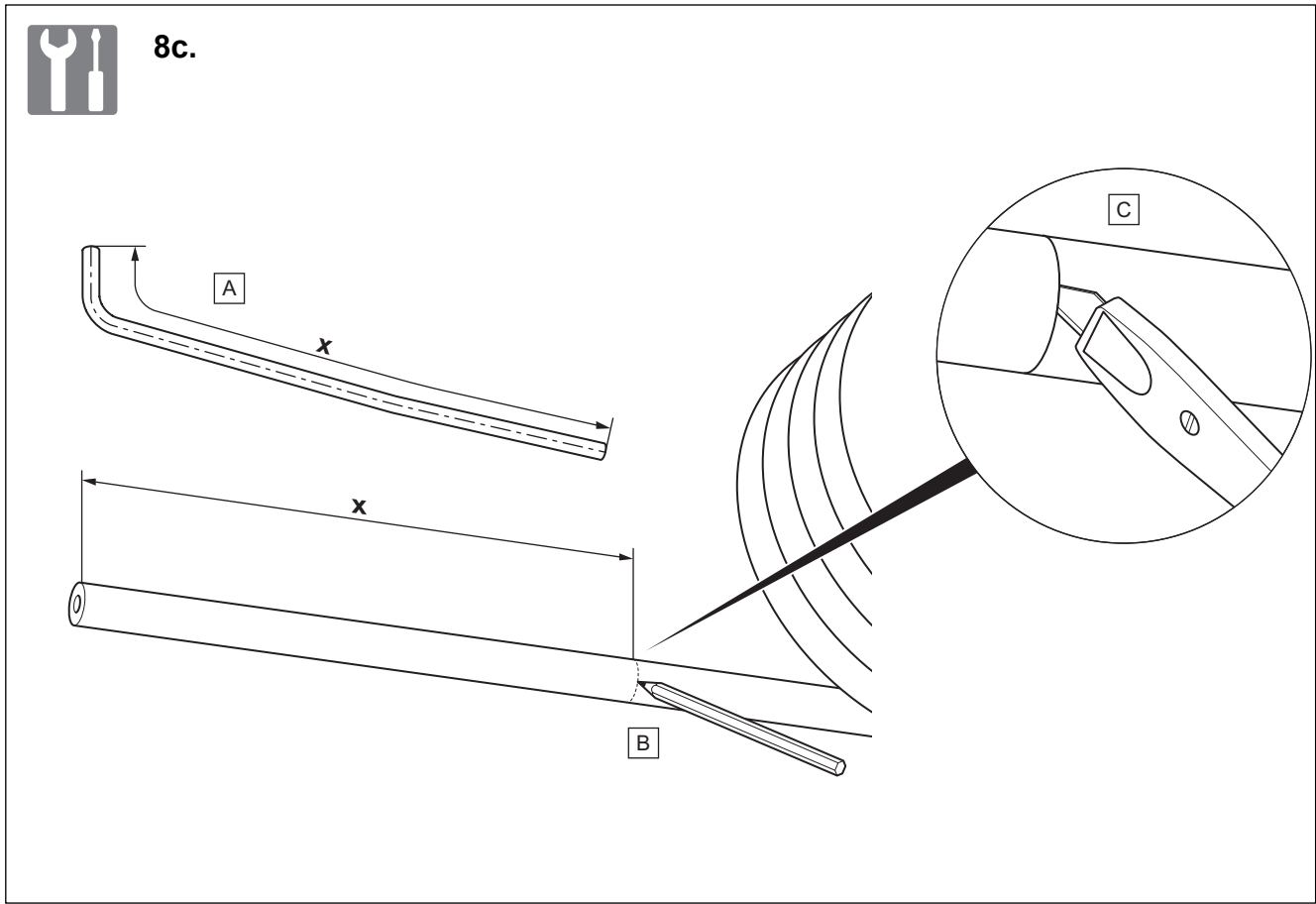

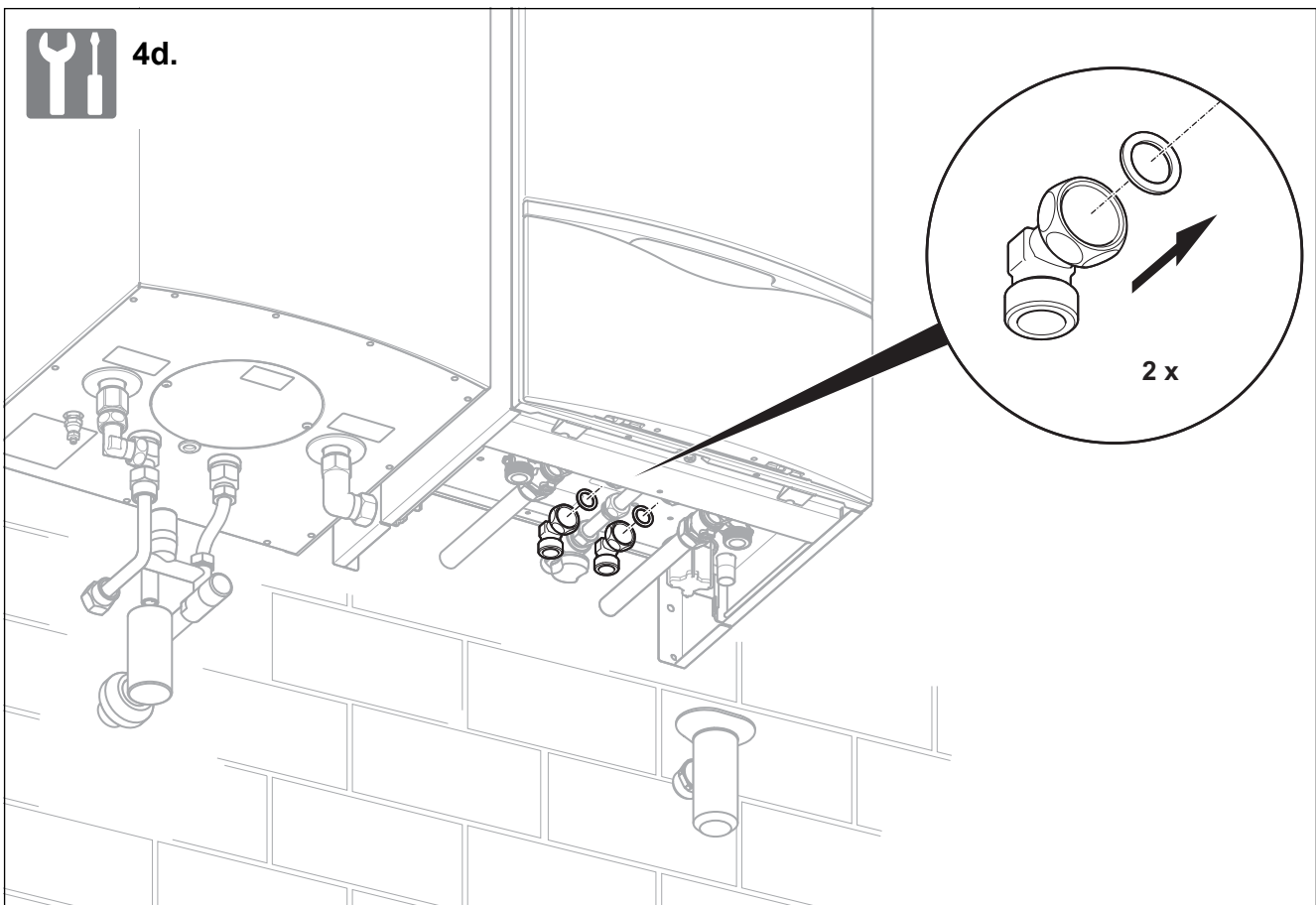
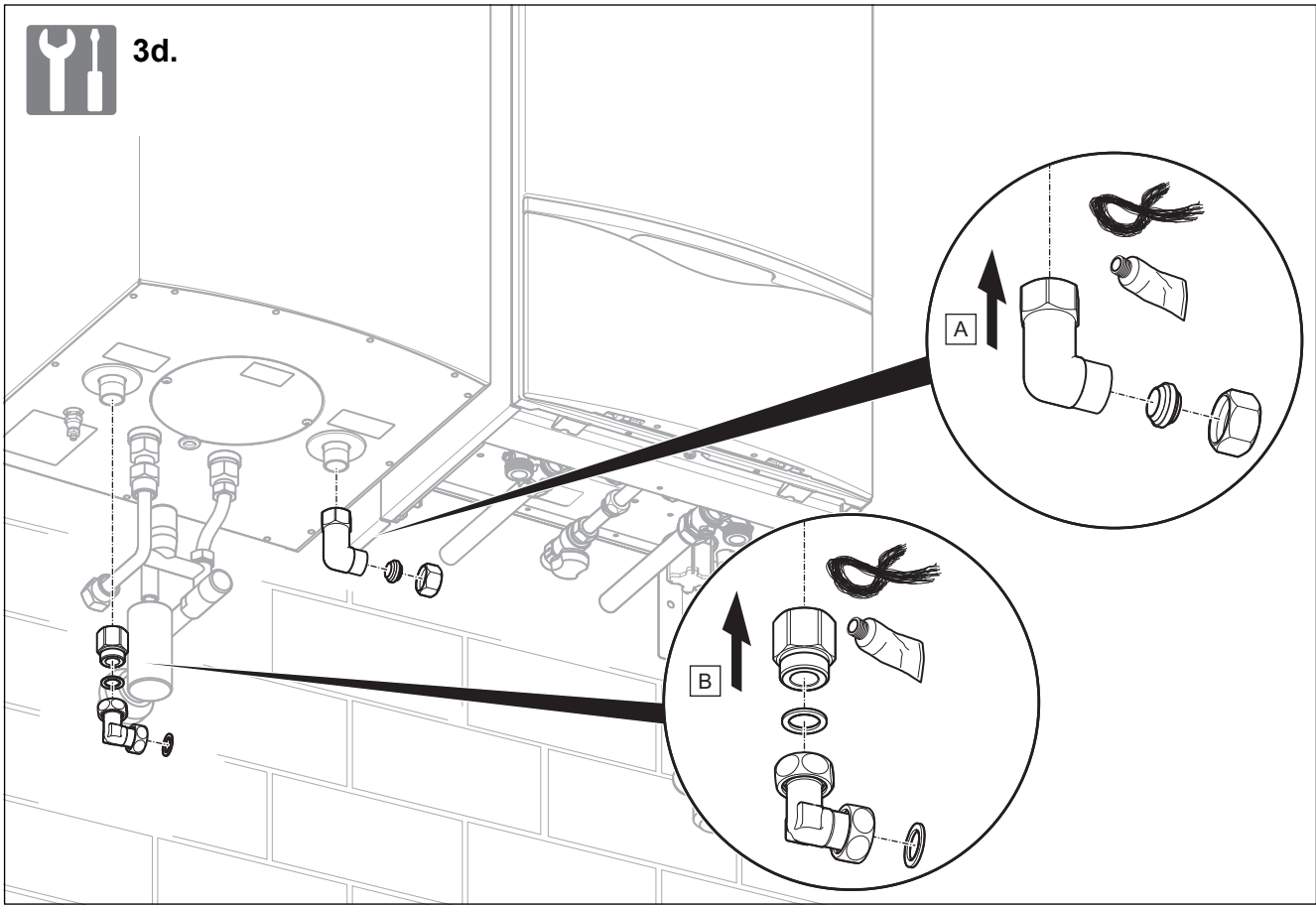

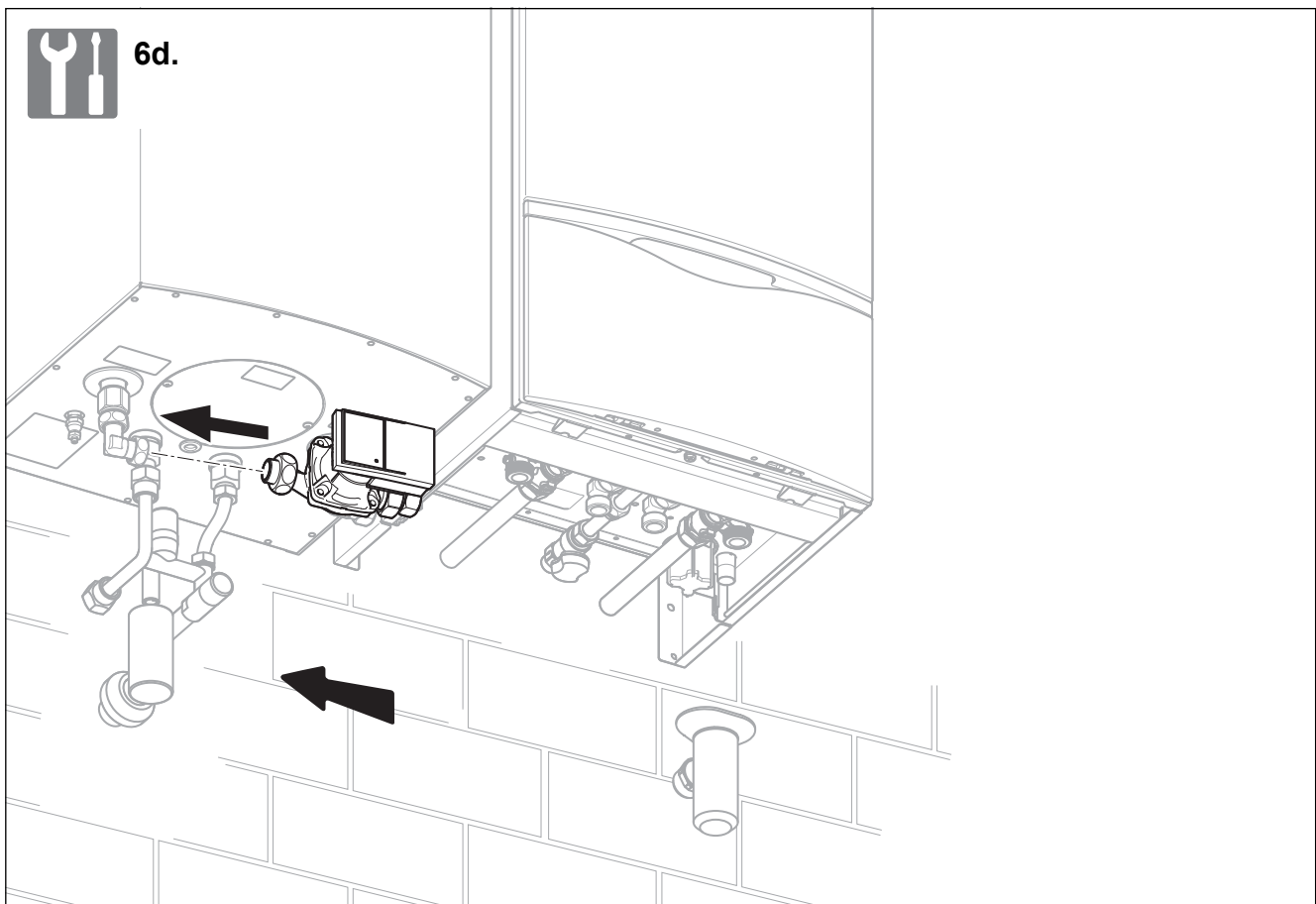
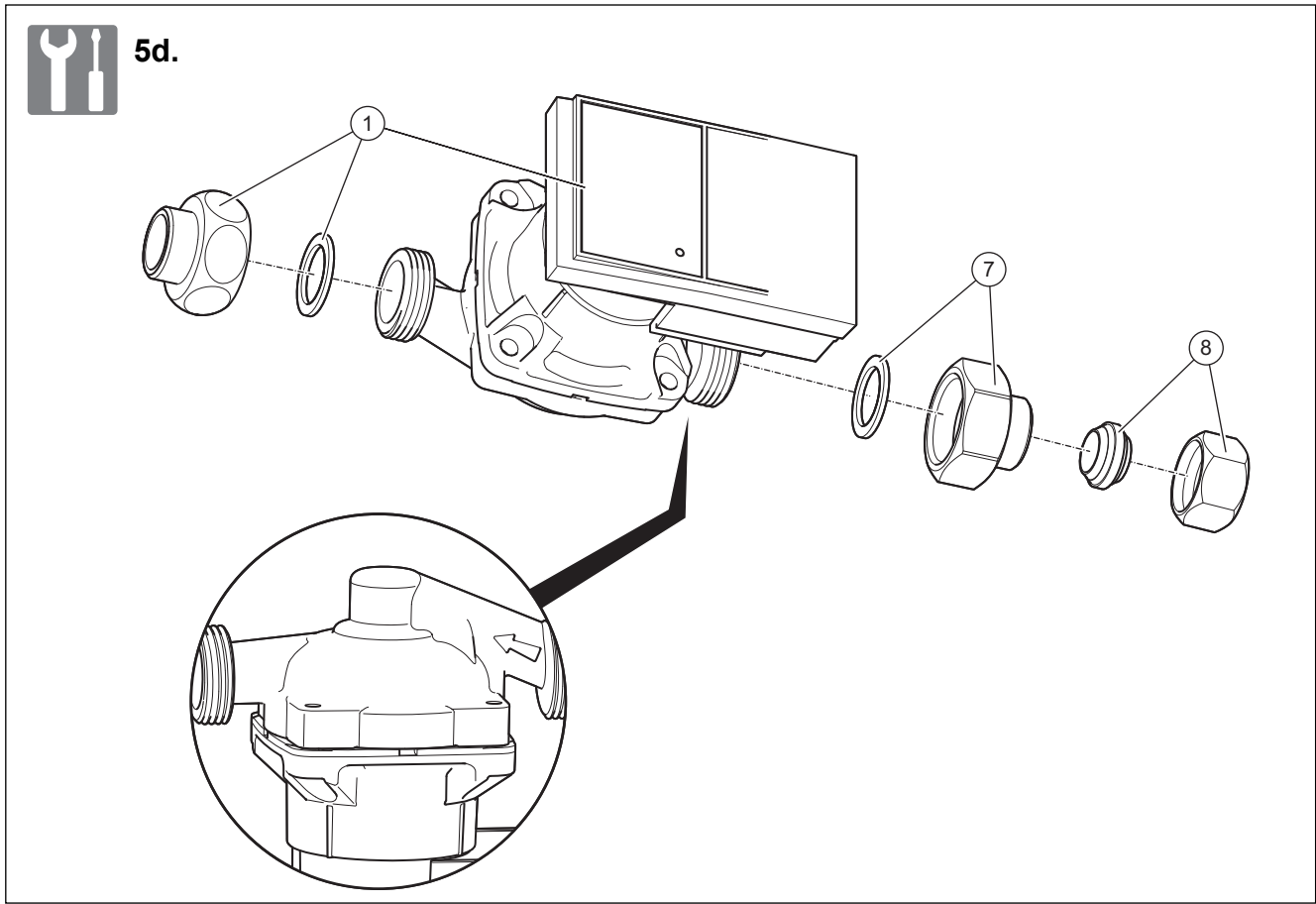

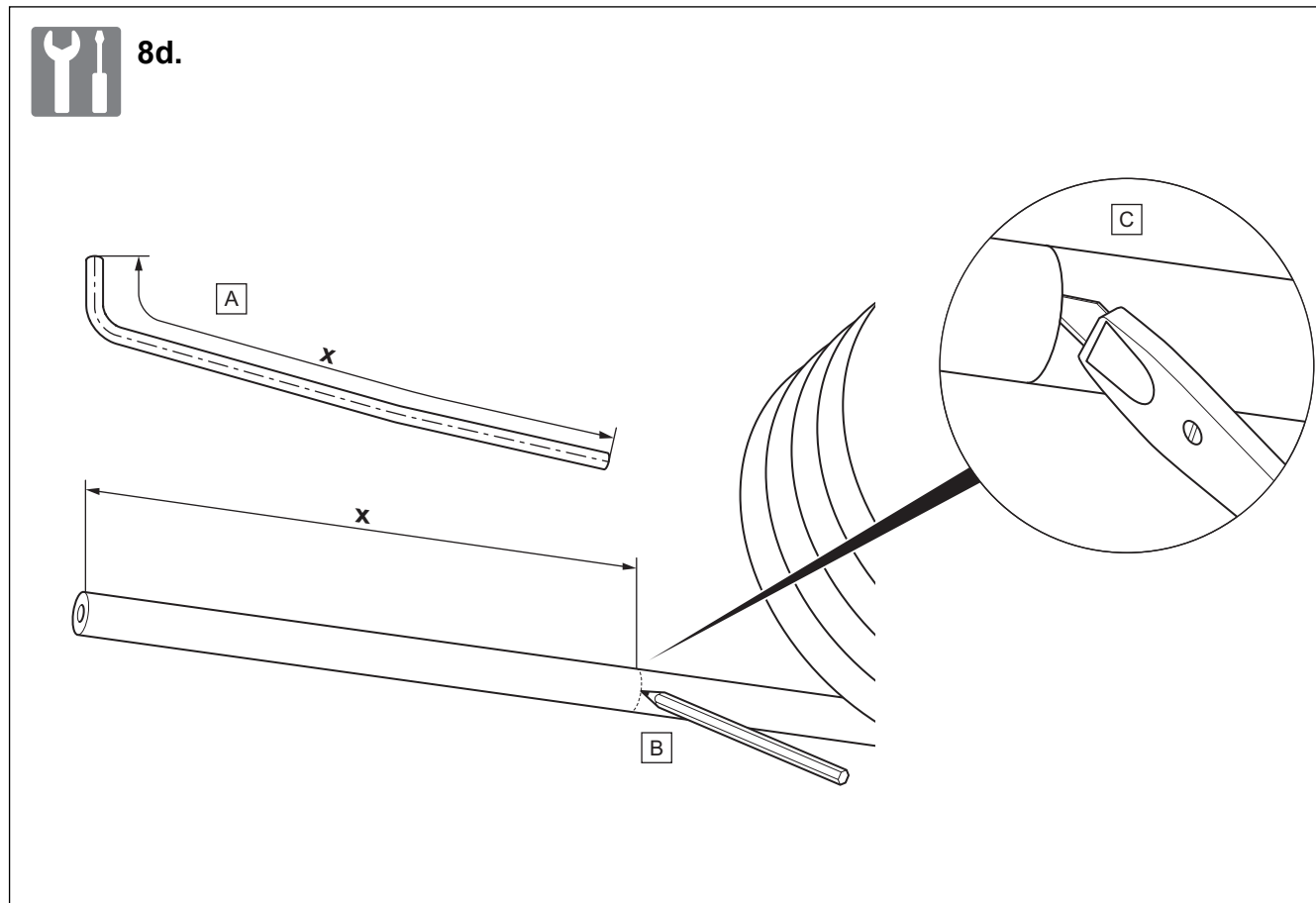
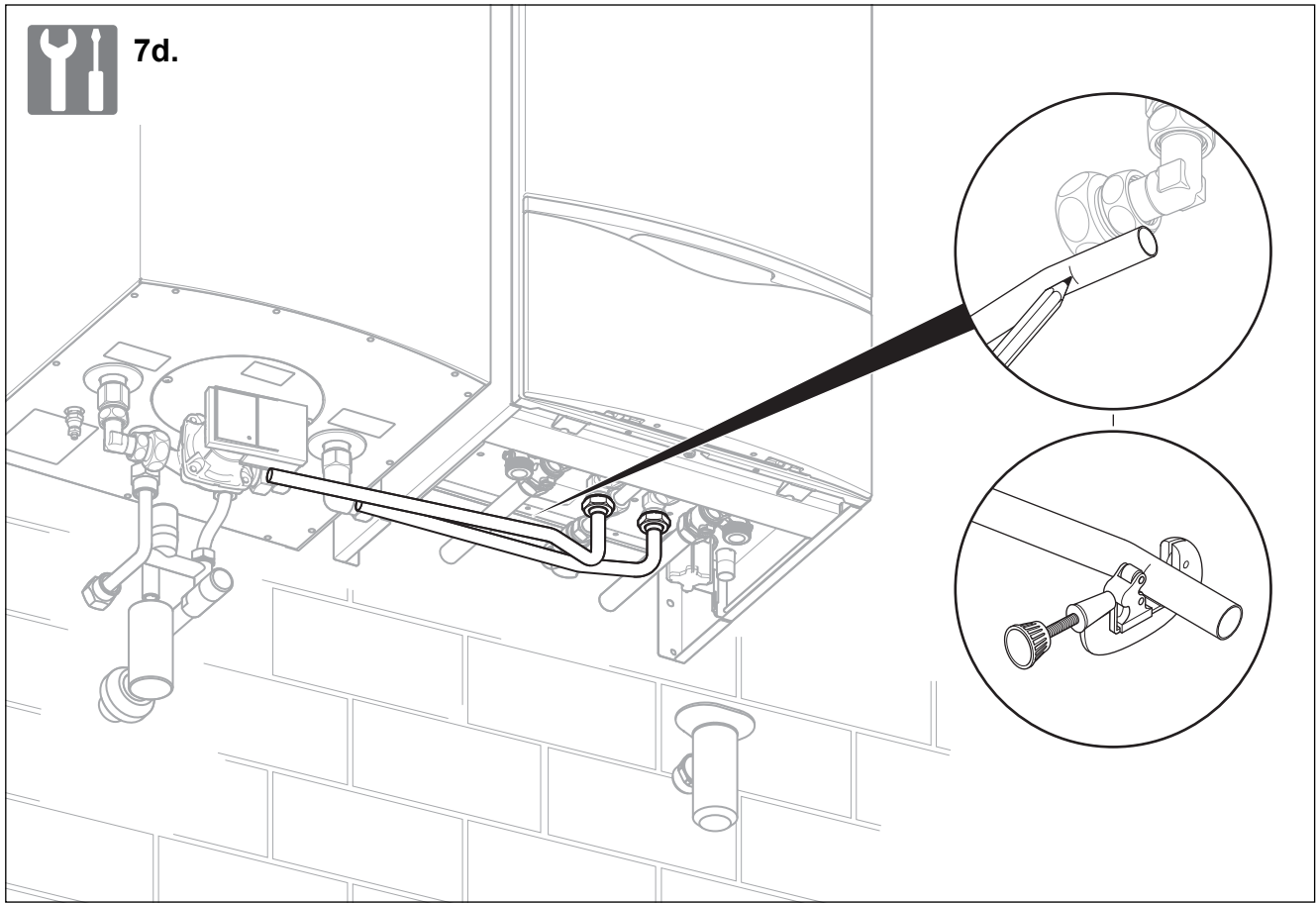

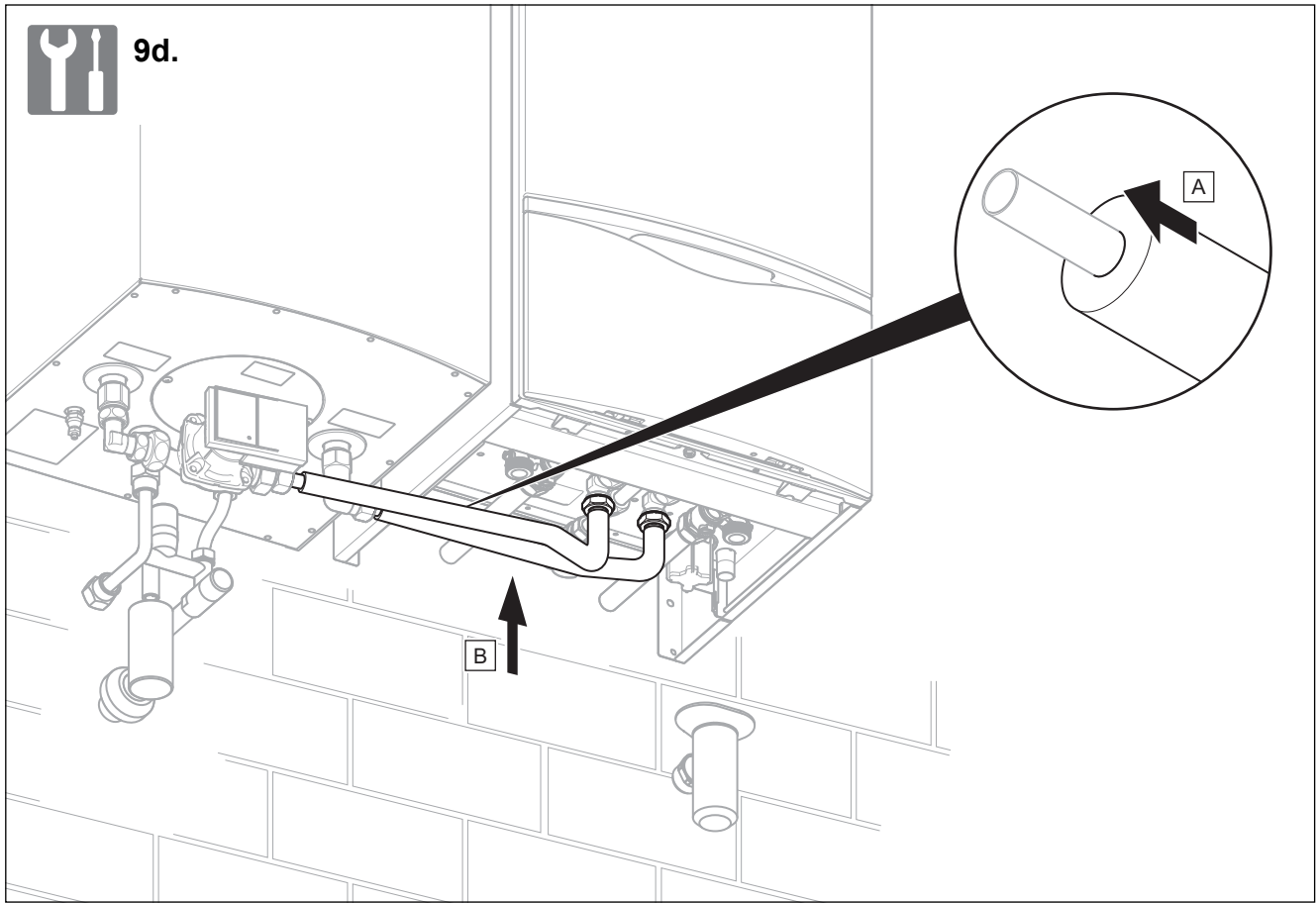

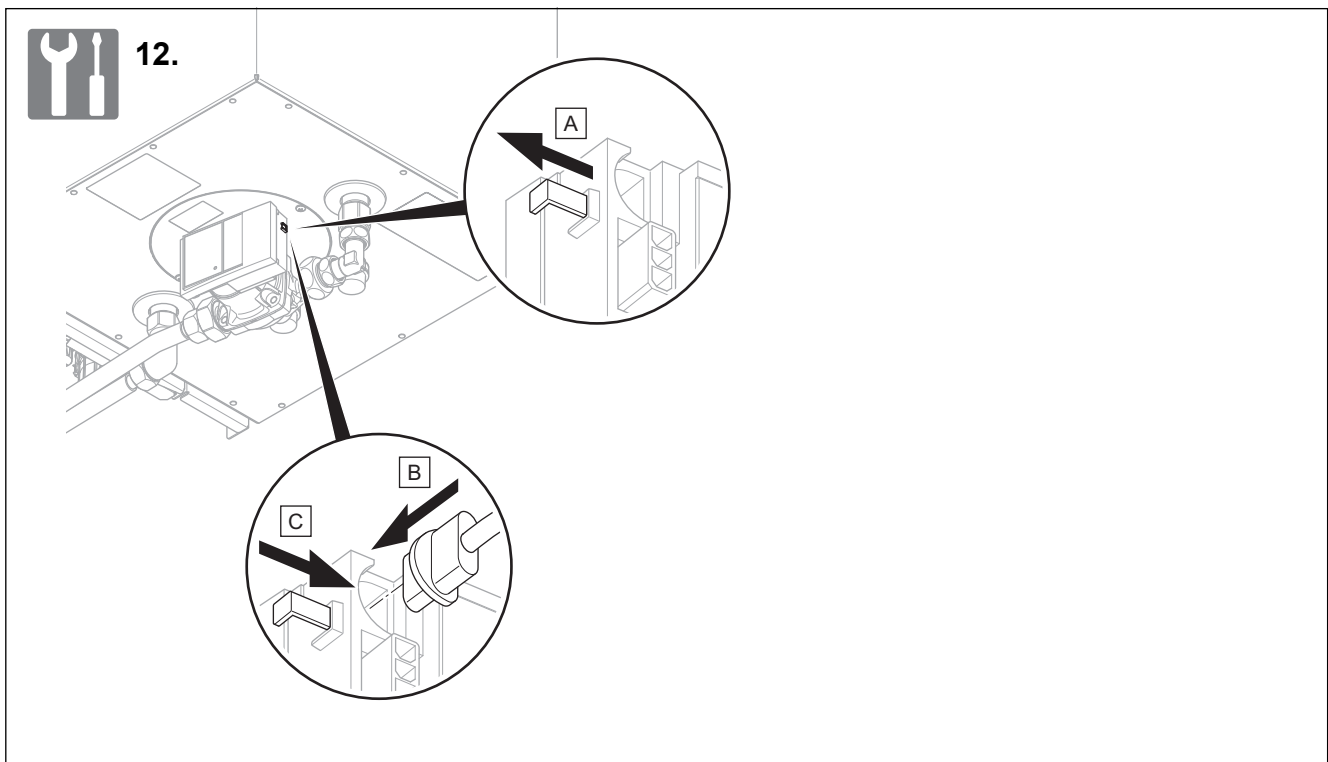
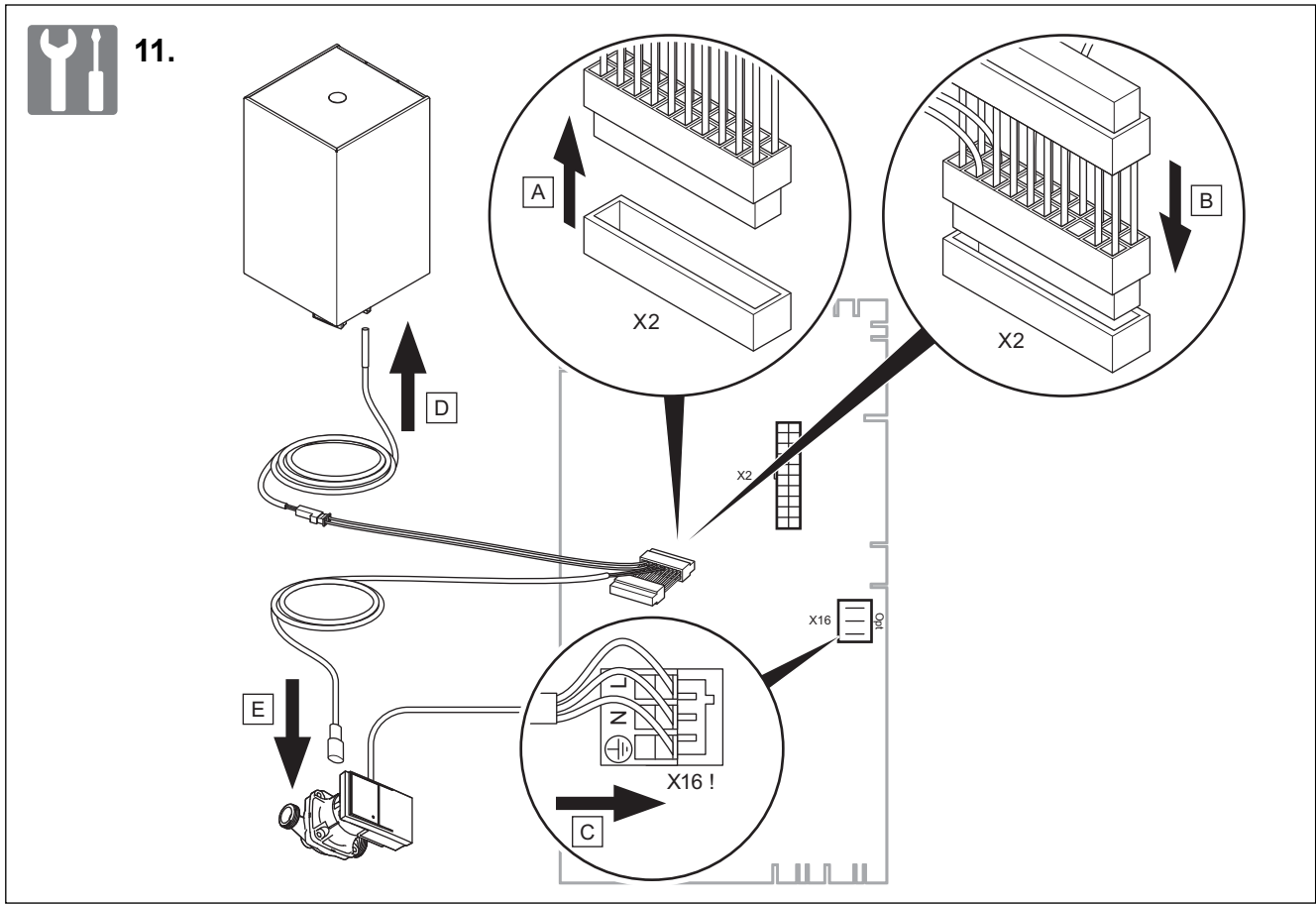

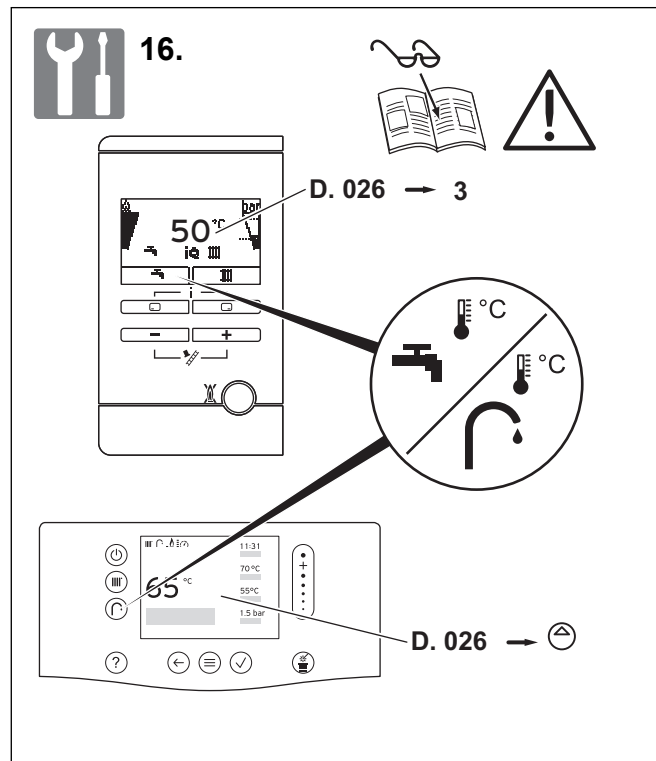
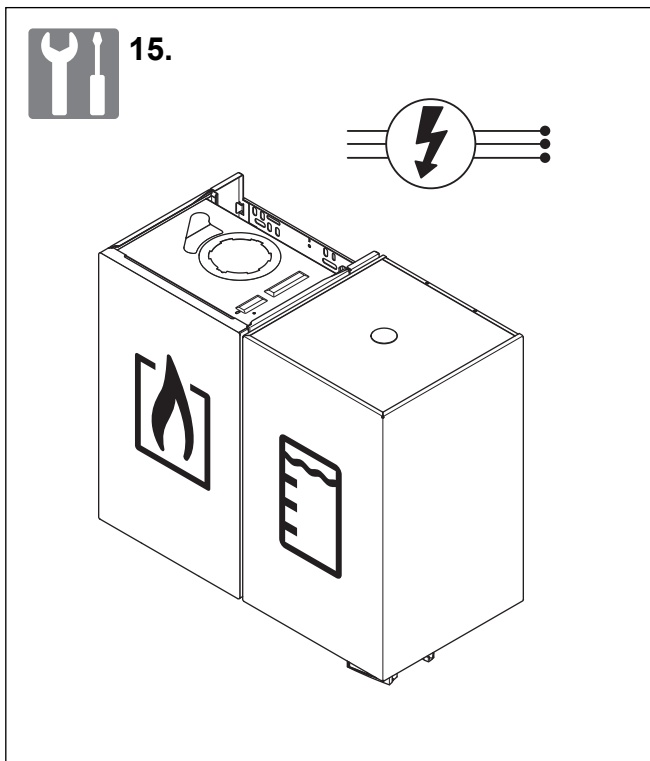
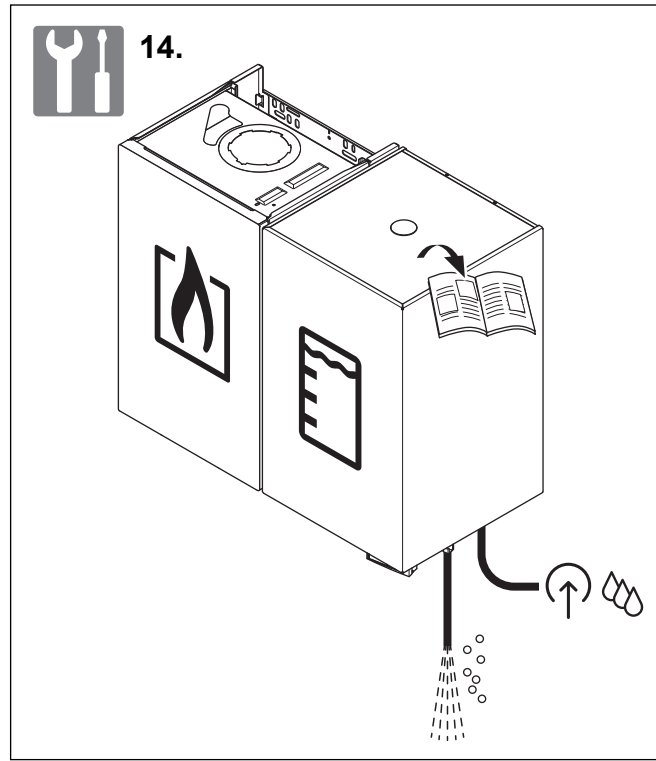
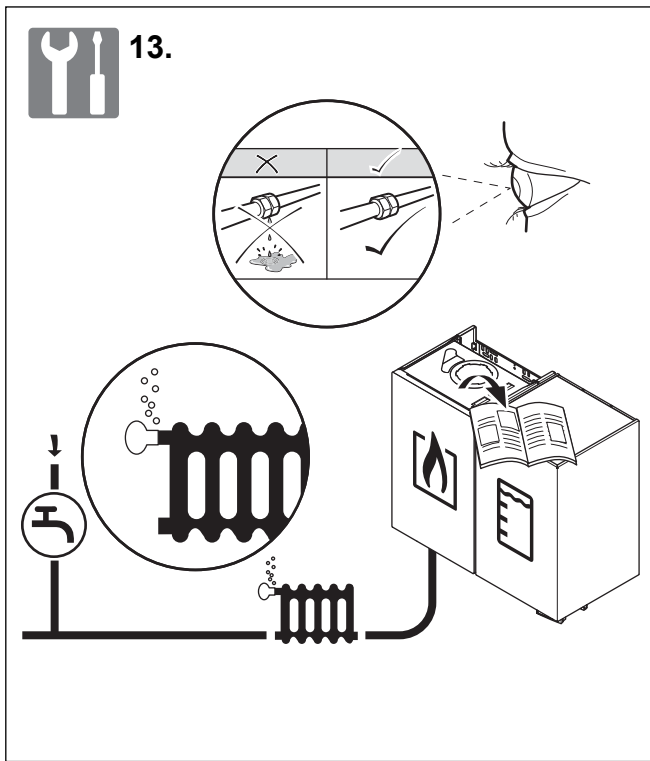

DE, AT, CHde

Installieren Sie, bei einem festverdrahteten Netzanschluss, eine alpolige Trennvorrichtung vom Netz mit einer Kontaktöffnungsweite von mindestens 3 mm pro Pol.

FR

En cas de raccordement câblé au réseau, installez un séparateur de réseau omnipolaire présentant un intervalle de coupure d'au moins 3 mm par pôle (par ex. fusibles ou interrupteur).

HU

Fix vezetékkel összekötött hálózati csatlakozás esetén szereljen be a hálózatról történő összpólusú leválasztás céljára egy pólusonként legalább 3 mm érintkezõnyitású leválasztó készüléket (pl. biztosíték vagy megszakító).

PL

W przypadku okablowanego na stałe przyłącza sieciowego należy instalować mułę przesuwną z wszystkimi biegunami do zasilania sieciowego przy szerokości rozwarcia zestyków min. 3 mm na jeden biegun (np. zabezpieczenia lub przełączniki mocy).

PT

No caso de uma ligação à rede elétrica por cabo, instale um dispositivo de separação da rede para todos os polos com uma amplitude da abertura de contacto mínima de 3 mm por polo (por ex. fusíveis ou interruptor de potência).

RU

При схемном подключении к электросети установите многополюсное разъединительное устройство от сети с расстоянием между контактами минимум 3 мм для каждого полюса (например, предохранители или силовые выключатели).

SI

Pri fiksni omrežni priključitvi vgradite ločilno napravo, ki zagotavlja prekinittev vseh polov z najmanj 3 mm razmika med kontakti vsakega pola (npr. varovalke ali odklopniki).

SK

Ak má siet'ová prípojka pevné pripojenie vodičmi, nainštalujte odpojovacie zariadenie na odpojenie od siete s roztvorením kontaktov minimálne 3 mm (napr. poistky alebo výkonový spínač).

NL

Installeer bij een bekabelde netwerkaansluiting een alpolige lastscheidingschakelaar met een contactopening van minimaal 3 mm per pool.



0020238816_01

Manufacturer

Vaillant GmbH

Berghauser Str. 40 ■ D-42859 Remscheid

Tel. +49 21 91 18-0 ■ Fax +49 21 91 18-28 10

www.vaillant.de ■ info@vaillant.de

0020238816_01 INT 022019 - Subject to technical modifications